

STATE OF NORTH CAROLINA  
**DEPARTMENT OF TRANSPORTATION**

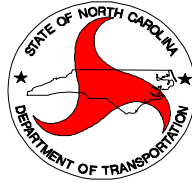

**REQUEST FOR PROPOSAL**  
**SMALL BUSINESS ENTERPRISE**

**DATE AND TIME OF BID OPENING: FEBRUARY 16, 2022 AT 2:00 P.M.**

**BID PROPOSAL NO.: 54-CA-08-12009199**

**WBS ELEMENT NOS.: VARIOUS**

**COUNTIES: RICHMOND, MONTGOMERY AND RANDOLPH – DIVISION 8**

**LOCATION: VARIOUS INTERSTATE, PRIMARY AND SECONDARY  
ROADS**

**TYPE OF WORK: LITTER/DEBRIS REMOVAL AND RECYCLING**

**DATE OF AVAILABILITY: MARCH 1, 2022**

**COMPLETION DATE: FEBRUARY 28, 2023**

**SMALL BUSINESS CERTIFICATION MANDATORY**

NOTICE: This is a Small Business Enterprise Program project, and as such, is restricted to businesses grossing less than \$1,500,000 during the previous calendar year (5% tolerance). A general Contractor's License is not required and the Department's normal bonding requirements are waived, however liability insurance is required. The attached self-certification form must be submitted with your proposal. A copy of the previous year's income tax return as evidence of qualification does not need to be submitted at this time, but could be required upon notification by the Department.

**PROPOSAL**  
**FOR THE CONSTRUCTION OF**  
**BID NO. 54-CA-08-12009199 IN RICHMOND, MONTGOMERY, AND RANDOLPH COUNTIES –**  
**DIVISION 8, NORTH CAROLINA**

**JANUARY 27, 2022**

**DEPARTMENT OF TRANSPORTATION,**  
**RALEIGH, NORTH CAROLINA**

The Bidder has carefully examined the location of the proposed work to be known as BID NO 54-CA-08-12009199; has carefully examined the plans and specifications, which are acknowledged to be part of the proposal, the special provisions, the proposal, the form of contract; and thoroughly understands the stipulations, requirements and provisions. The undersigned bidder agrees to bound upon his execution of the bid and subsequent award to him by the Department of Transportation in accordance with this proposal. The undersigned Bidder further agrees to provide all necessary machinery, tools, labor, and other means of construction; and to do all the work and to furnish all materials, except as otherwise noted, necessary to perform and complete the said contract in accordance with *the 2018 Standard Specifications for Roads and Structures* by the dates(s) specified in the Project Special Provisions and in accordance with the requirements of the Engineer, and at the unit or lump sum prices, as the case may be, for the various items given on the sheets contained herein.

The Bidder shall provide and furnish all the materials, machinery, implements, appliances and tools, and perform the work and required labor to construct and complete State Highway BID NO. 54-CA-08-12009199, for the unit or lump sum prices, as the case may be, bid by the Bidder in his bid and according to the proposal, plans, and specifications prepared by said Department, which proposal, plans, and specifications show the details covering this project, and hereby become a part of this contract.

The published volume entitled *North Carolina Department of Transportation, Raleigh, Standard Specifications for Roads and Structures, January 2018* with all amendments and supplements thereto, is by reference incorporated into and made a part of this contract; that, except as herein modified, all the construction and work included in this contract is to be done in accordance with the specifications contained in said volume, and amendments and supplements thereto, under the direction of the Engineer.

If the proposal is accepted and the award is made, the contract is valid only when signed either by the Contract Officer or such other person as may be designated by the Secretary to sign for the Department of Transportation. The conditions and provisions herein cannot be changed except over the signature of the said Contract Officer or Division Engineer.

The quantities shown in the itemized proposal for the project are considered to be approximate only and are given as the basis for comparison of bids. The Department of Transportation may increase or decrease the quantity of any item or portion of the work as may be deemed necessary or expedient.

An increase or decrease in the quantity of an item will not be regarded as sufficient ground for an increase or decrease in the unit prices, nor in the time allowed for the completion of the work, except as provided for the contract.

**TABLE OF CONTENTS**

<b>PROJECT SPECIAL PROVISIONS - GENERAL</b>	<b>PAGE NO.</b>
General	5
Small Business Enterprise (SBE) Contract	5
General Contractors Licensing Requirements	6
Contract Time	6
Term of Contract	6
Award of Contract	6
Basis of Award	7
Quantities Estimated	7
Bond Requirements	7
Small Business Enterprise Multi-Year Maintenance Contracts	7
Intermediate Contract Time Number 1 and Liquidated Damages	7
Intermediate Contract Time Number 2 and Liquidated Damages	8
Intermediate Contract Time Number 3 and Liquidated Damages	8
Progress and Prosecution	9
Traffic Control and Work Zone Safety	9
Safety Vests	10
Supervision by Contractor	10
Insurance	10
Responsibility for Damage Claims	10
Payment and Retainage	11
<b>PROJECT SPECIAL PROVISIONS - ROADWAY</b>	<b>PAGE NO.</b>
Litter/Debris Removal and Recycling	11
Reporting	13
Hazardous, Contaminated, and/or Toxic Material	14
Mobilization	14
Safety	14
Equipment Requirements	15
Equipment Idling Guidelines	15
Deletion of Sections	16
Bid Items	16
Quality, Inspection and Basis of Acceptance	17
Method of Measurement	17
Basis of Payment	18
<b>STANDARD SPECIAL PROVISIONS</b>	<b>PAGE NO.</b>
Availability of Funds – Termination of Contracts	19
Authority of the Engineer	19
Minimum Wages	19
Erosion Control	20
Work Zone Signing	20
Plant and Pest Quarantines	20
Bankruptcy	21
Subletting of Contract	21
Debarment Statement	21
Default of Contract	21
Cooperation between Contractors	21
No Major Contract Items	21

No Specialty Items	21
Utility Conflicts	22
Driveways and Private Property	22
Outsourcing Outside the USA	22
Title VI and Nondiscrimination	22

<b>APPENDIX</b>	<b>PAGE NO.</b>
Work Zone Guidance for Litter/Debris Removal	29
General	29
Exceptions	30
Work Zone Signing	30
Sign Detail	31
Service Vehicles	32
Typical Sections	33
Operations Diagrams	34
Breakdown of Routes and Mileage	42

<b>INSTRUCTIONS TO BIDDERS</b>	<b>PAGE NO.</b>
Preparation and Submission of Traditional Paper Bids	44
Opening of Bids	45

<b>BID SUBMITTAL PACKAGE</b>	<b>PAGE NO.</b>
Cover Sheet	1
Contract Bid Form	2
Contractor Information	3
Federal Employer Identification Number	4
Contractor's Work Experience and References	5
Execution of Bid Non-Collusion, Debarment and Gift Ban Certification	6
Bid Submittal Package Checklist	14

## **PROJECT SPECIAL PROVISIONS - GENERAL**

### **GENERAL**

This contract is for litter/debris removal and recycling on interstate, primary and secondary roads and their interchanges in Richmond and Montgomery Counties, and litter removal and recycling on secondary roads only in Randolph County in Division 8. The Contractor is to provide all equipment, labor and material.

All materials and workmanship shall be in accordance with the following:

The Project Special Provisions, Project Standard Provisions, most current Standard Special Provisions, *Manual of Uniform Traffic Control Devices (MUTCD)*, Provisions contained in the applicable Sections of the North Carolina Department of Transportation's *2018 Standard Specifications for Roads and Structures* and Drawings contained in the applicable sections of the North Carolina Department of Transportation's *2018 Roadway Standard Drawings* shall apply.

The published volume entitled *North Carolina Department of Transportation, Standard Specifications for Roads and Structures*, with all amendments and supplements thereto, is by reference incorporated into and made a part of this contract; that, except as herein modified, all the construction and work included in the contract is to be done in accordance with the specifications contained in said volume, and amendments and supplements thereto, under the direction of the Engineer.

The Contractor shall keep himself fully informed of all Federal, State, and local laws, ordinances, and regulations, and shall comply with the provisions of Section 107 of the *Standard Specifications*.

These manuals may be found at the following websites: <http://mutcd.fhwa.dot.gov/> and <https://connect.ncdot.gov/resources/Specifications/Pages/2018-Specifications-and-Special-Provisions.aspx>.

### **SMALL BUSINESS ENTERPRISE (SBE) CONTRACT**

The Department of Transportation does not exclude any person from participation in, deny any person the benefits of, or otherwise discriminate against anyone in connection with the award and performance of any contract covered by this program on the basis of race, color, sex, political affiliation/influence, or national origin.

This is a SBE contract and to qualify for the NCDOT SBE Program a firm must have an annual gross income of \$1,500,000 or less, exclusive of materials. **Only contractors currently certified as a SBE Contractor by the NCDOT Office of Civil Rights SBE Program Manager and listed in the Directory of Transportation Firms at bid opening will be eligible to bid on this project.**

If unsure as to whether a firm is currently certified by NCDOT, search the Directory of Transportation Firms at the following website: <https://www.ebs.nc.gov/VendorDirectory/default.html>.

Bids received from firms that are not certified as SBE Contractors through NCDOT Office of Civil Rights SBE Program Manager will not be opened.

**Prospective bidders who qualify for the SBE Program and are not currently certified should submit a completed application packet to the SBE Program Manager prior to bid submittal to allow for review time.** Additional information on the program, including the application to become certified, may be obtained online at the following website:

<https://connect.ncdot.gov/business/SmallBusiness/Pages/default.aspx>

Bidders must renew their SBE status and recertify each year. It is the bidder's responsibility to ensure that their existing SBE status does not lapse prior to bid opening (or beginning work as a subcontractor). **Advance notification of pending renewal dates is not guaranteed.**

Per G.S. 136-28.10, a NC General Contractor's license may be waived for SBE contracts. For this project, the NC General Contractor's license will be waived. Per G.S. 136-28.10, contract payment and performance bonds may be waived. For this project, the contract payment and performance bonds will be waived.

### **CONTRACT TIME**

The date of availability for this contract is **March 1, 2022**.

No work will be permitted and no purchase order will be issued until all required bonds and prerequisite conditions and certifications have been satisfied.

The completion date for this contract is **February 28, 2023**. The Contractor shall submit his/her bid for one (1) year.

### **TERM OF CONTRACT**

This contract shall be effective for one (1) contract period. The contract period will last from the availability date to the completion date, as noted above.

At the sole option and discretion of the contracting agency, North Carolina Department of Transportation (NCDOT), and upon written notification, this contract may be extended for two (2) additional periods, one (1) year each, unless a shorter time is mutually agreed upon by the parties, (maximum of three years total). Extensions for additional term(s) are not guaranteed. Each line item bid price will be increased for each one (1) year extension by two (2) percent of the current price. No changes in the terms, conditions, etc. of this contract will be made when an extension to the contract is implemented. Including all renewals, the total contract expenditures shall not exceed the maximum purchase order value of \$5 million.

The Contractor will be notified within sixty (60) days before expiration of the contract if NCDOT chooses not to offer an extension. Upon receipt of notification, the Contractor must notify the Engineer in writing within thirty (30) days the contract completion date of his/her acceptance or rejection of this offer. Failure on the part of the Contractor to reply will be considered a rejection of the contract extension. NCDOT is under no obligation to renew this contract beyond its original one (1) year period.

### **AWARD OF CONTRACT**

(6-28-77)(Rev 2/16/2018)

Z-6

"The North Carolina Department of Transportation, in accordance with the provisions of *Title VI of the Civil Rights Act of 1964* (78 Stat. 252) and the Regulations of the Department of Transportation (*49 C.F.R., Part 21*), issued pursuant to such act, hereby notifies all bidders that it will affirmatively insure that the contract entered into pursuant to this advertisement will be awarded to the lowest responsible bidder without discrimination on the ground of race, color, or national origin".

All eligible proposals will be evaluated and acceptance made of the bid judged in the discretion of the contracting agency to determine the lowest responsible bidder for the purpose intended. The Contracting Agency using its discretion, will determine whether a bidder is a "responsible" bidder. In determining whether a bidder is "responsible, the Contracting Agency will evaluate, the bid price, completeness and content of the bid, Bidder's related work experience, ability of the Bidder and staff to perform the services required, Bidder's past performance, references, and Bidder's financial stability. After opening bids and prior to award, the Contracting Agency may also seek supporting documentation prior to determining whether a bidder is a "responsible" bidder. No changes in bid price or price negotiations will be allowed after bids are opened and prior to an award. After the Contracting Agencies evaluation, the award of the contract, if awarded, will be made to the lowest responsible bidder. The lowest responsible bidder will be notified that his bid has been accepted and that he has been awarded the contract. Withdrawal of proposal will be allowed only under limited conditions. If a Bidder is awarded a contract, he/she

will be expected to perform the work. Failure to perform may result in the Bidder being held in default of contract. In the event of default, the Department may, in its discretion, contact the next lowest responsible bidder to determine whether that next lowest responsible bidder is willing and able to complete the contract at its bid price.

All awards are final and are not subject to further review. Any formal complaints concerning awards should be made in writing to the Engineer.

### **BASIS OF AWARD**

Quantities for this work are estimated and are not guaranteed. Determination of the apparent low bidder will be made by extending the unit prices quoted on the Bid Proposal Form.

**Unit prices shall reflect actual costs; unbalanced bids may be rejected per the North Carolina Department of Transportation's 2018 Standard Specifications for Roads and Structures.**

### **QUANTITIES ESTIMATED**

The quantities shown on the itemized bid form are considered to be approximate only and are given as the basis for comparison of bids. For accounting purposes only a purchase order may contain quantity amounts and they SHALL NOT be construed as minimum quantities. Quantities shall be determined solely by the Department on an "as needed" basis. In the event of a conflict between any purchase orders and this proposal, this proposal shall control. An increase or decrease in quantities shall not be cause for an adjustment in unit prices.

### **SMALL BUSINESS ENTERPRISE (MULTI-YEAR MAINTENANCE CONTRACTS):**

(4-20-21)

SP1 G74

This contract is a multi-year maintenance contract let pursuant to the Small Business Enterprise provisions of N.C. General Statute §136-28.10. In accordance with N.C. General Statute §136-28.10, an award in a maintenance contract shall not exceed \$500,000 per year. This contract award is limited to \$500,000 per year. No payments in excess of this amount will be disbursed, in accordance with the Statute.

### **BOND REQUIREMENTS**

The provisions of Articles 102-10 and 103-7 of the 2018 Standard Specifications for Roads and Structures are waived for this project. No bonds required.

### **INTERMEDIATE CONTRACT TIME NUMBER 1 AND LIQUIDATED DAMAGES**

The Contractor shall not work within the roadway or associated right of way on **ANY STATE MAINTAINED ROUTE**, detain and /or alter the traffic flow on or during holiday weekends, special events, or any other time when traffic is unusually heavy, including the following schedules:

#### **HOLIDAY AND HOLIDAY WEEKEND WORK RESTRICTIONS:**

1. For **unexpected occurrence** that creates unusually high traffic volumes, as directed by the Engineer.
2. For **New Year's Day**, between the hours of **4:00 p.m.** December 31st and **8:30 a.m.** January 2nd. If New Year's Day is on a Friday, Saturday, Sunday or Monday, then until **8:30 a.m.** the following Tuesday.
3. For **Martin Luther King, Jr. Day**, between the hours of **4:00 p.m.** Friday and **8:30 a.m.** Tuesday.
4. For **Easter**, between the hours of **4:00 p.m.** Thursday and **8:30 a.m.** Monday.
5. For **Memorial Day**, between the hours of **4:00 p.m.** Friday and **8:30 a.m.** Tuesday.
6. For **Independence Day**, between the hours of **4:00 p.m.** the day before Independence Day and **8:30 a.m.** the day after Independence Day.

If **Independence Day** is on a Friday, Saturday, Sunday or Monday, then between the hours of **4:00 p.m.** the Thursday before Independence Day and **8:30 a.m.** the Tuesday after Independence Day.

7. For **Labor Day**, between the hours of **4:00 p.m.** Friday and **8:30 a.m.** Tuesday.
8. For **Veteran's Day**, between the hours of **4:00 p.m.** Friday and **8:30 a.m.** Tuesday.
9. For **Thanksgiving Day**, between the hours of **4:00 p.m.** Tuesday and **8:30 a.m.** Monday.
10. For **Christmas**, between the hours of **4:00 p.m.** the Friday before the week of Christmas Day and **8:30 a.m.** the following Tuesday after the week of Christmas Day.

Holidays and holiday weekends shall include New Years, Easter, Memorial Day, Independence Day, Labor Day, Thanksgiving, and Christmas. The Contractor shall schedule his work so that work is not required during these periods, unless otherwise directed by the Engineer.

Hours of work are restricted to daylight hours. No work will be allowed on Sundays unless approved in writing by the Engineer.

Liquidated damages for this contract are **Two Hundred Fifty Dollars (\$250.00)** per hour or portion thereof that the Contractor operates outside of the work hours as stated above.

### **INTERMEDIATE CONTRACT TIME NUMBER 2 AND LIQUIDATED DAMAGES**

The Contractor shall complete the work required for the Routine Litter/Debris Removal and Recycling on all routes identified in the proposal documents under "Litter/Debris Removal and Recycling Plans" and shall place and maintain traffic on same.

The date of availability for this intermediate contract time is the first day of each two (2) month period for routes designated for monthly cleanups.

The Contractor will be required to prosecute the work in a continuous and uninterrupted manner until the entire section/route is complete.

The liquidated damages are **One Hundred Dollars (\$100.00)** per calendar day each day no work is performed. This does not include inadequate visibility/weather conditions.

The completion date for bi-monthly cleanups is the last day of the second month.

The liquidated damages are **One Hundred Dollars (\$100.00)** per calendar day and will continue until that cycle is completed.

The Contractor shall remove all bags and piles of refuse by the end of the work day unless approved by the Engineer or his/her representative. The liquidated damages for not complying with the removal of litter/debris will be **Two Hundred Fifty Dollars (\$250.00)** per calendar day.

### **INTERMEDIATE CONTRACT TIME NUMBER 3 AND LIQUIDATED DAMAGES**

The Contractor shall complete the work required for the On Call Litter/Debris Removal and Recycling, Outside Shoulder and/or On Call Litter/Debris Removal and Recycling, Median on all routes as identified by the Engineer and shall place and maintain traffic on same.

The date of availability for this intermediate contract time is within forty-eight (48) hours of notification.

The liquidated damages for failing to begin work within the specified time frame is **Two Hundred Fifty Dollars (\$250.00)** per calendar day beginning forty-eight (48) hours after notification and continuing until work begins.



The Contractor will be required to prosecute the work in a continuous and uninterrupted manner from the time work begins until completion and final acceptance of the additional work.

### **PROGRESS AND PROSECUTION**

The Contractor will be required to prosecute the work in a continuous and uninterrupted manner from the time he begins the work until completion and final acceptance of the project. The Contractor will not be permitted to suspend his operations except for reasons beyond his control or except where the Engineer has authorized a suspension of the Contractor's operations in writing.

It is further the intent that the Contractor shall pursue the work diligently with workmen in sufficient numbers, abilities, and supervision, and with the equipment, materials, and methods of construction as may be required to complete the work described in the contract, or as may be amended, by the completion date and in accordance with Section 108 of the Standard Specifications.

The Contractor's vehicles and equipment shall not be parked within the State Highway System right of way overnight or at other times when work has been suspended unless approved by the Engineer, and in no case within 30 feet of the edge of pavement. The Engineer may designate specific locations for parking equipment.

The Contractor shall adhere to all applicable regulations and follow accepted safety procedures when working in the vicinity of utilities in order to insure the safety of construction personnel and the public.

In the event that the Contractor's operations are suspended in violation of the above provisions, the sum of **Five Hundred (\$500.00)** will be charged to the contractor for each and every calendar day that such suspension takes place. The said amount is hereby agreed upon as liquidated damages. Liquidated damages chargeable due to suspension of the work will be additional to any liquidated damages that may become chargeable due to failure to complete the work by the completion date

### **TRAFFIC CONTROL AND WORK ZONE SAFETY**

The Contractor shall maintain traffic during construction and provide, install, and maintain all traffic control devices in accordance with these project guidelines, the Project Traffic Control Plans, the Project Special Provisions, North Carolina Department of Transportation Standard Specifications for Roads and Structures 2018, and the current edition of the Manual of Uniform Traffic Control Devices (MUTCD).

The Contractor shall utilize complete and proper traffic controls and traffic control devices during all operations. All traffic control and traffic control devices required for any operation shall be functional and in place prior to the commencement of that operation. Signs for temporary operations shall be removed during periods of inactivity. The Contractor is required to leave the project in a manner that will be safe to the traveling public and which will not impede motorists.

Traffic movements through lane closures on roads with two way traffic shall be controlled by flaggers stationed at each end of the work zone. In situations where sight distance is limited, the Contractor shall provide additional means of controlling traffic, including, but not limited to, two-way radios, pilot vehicles, or additional flaggers. Flaggers shall be competent personnel, adequately trained in flagging procedures, and furnished with proper safety devices and equipment, including, but not limited to, safety vests and stop/slow paddles.

All personnel when working in traffic areas or areas in close proximity to traffic shall wear an approved safety vest, or shirt or jacket which meets the color requirements of the Manual of Uniform Traffic Control Devices (MUTCD).

The Contractor shall comply with all applicable Federal, State, and local laws, ordinances, and regulations governing safety, health, and sanitation, and shall provide all safeguards, safety devices, and protective equipment,

and shall take any other needed actions, on his own responsibility that are reasonably necessary to protect the life and health of employees on the job and the safety of the public, and to protect property in connection with the performance of the work covered by the contract.

Failure to comply with any of the requirements for safety and traffic control of this contract shall result in suspension of work as provided in Subarticle 108-7(2) of the Standard Specifications.

The Contractor's vehicles and equipment shall not be parked within the State Highway System right of way overnight or at other times when work has been suspended unless approved by the Engineer, and in no case within 30 feet of the edge of pavement. The Engineer may designate specific locations for parking equipment.

Traffic Control will be incidental to the work, and will be included in the unit bid price for the other items included in the contract.

### **SAFETY VESTS**

All Contractor's personnel, all subcontractors and their personnel, and any material suppliers and their personnel, must wear a reflective safety vest or outer garment meeting ANSI/ISEA 107-2004 Class 2 standards at all times while on the project.

### **SUPERVISION BY CONTRACTOR**

At all times during the life of the project the Contractor shall provide one permanent employee who shall have the authority and capability for overall responsibility of the project and who shall be personally available at the work site within 24 hours' notice. Such employee shall be fully authorized to conduct all business with the subcontractors, to negotiate and execute all supplemental agreements, and to execute the orders or directions of the Engineer.

At all times that work is actually being performed, the Contractor shall have present on the project one competent individual who is authorized to act in a supervisory capacity over all work on the project, including work subcontracted. The individual who has been so authorized shall be experienced in the type of work being performed and shall be fully capable of managing, directing, and coordinating the work; of reading and thoroughly understanding the contract; and receiving and carrying out directions from the Engineer or his authorized representatives. He shall be an employee of the Contractor unless otherwise approved by the Engineer.

The Contractor may, at his option, designate one employee to meet the requirements of both positions. However, whenever the designated employee is absent from the work site, an authorized individual qualified to act in a supervisory capacity on the project shall be present.

### **INSURANCE**

The Contractor shall maintain all legally required insurance coverage, including without limitation, worker's compensation and vehicle liability, in the amounts required by law. Refer to Section 107-15 in the "*Standard Specifications for Roads and Structures, 2018*" for additional information.

### **RESPONSIBILITY FOR DAMAGE CLAIMS**

In accordance with 107-14 of the Standard Specifications. The Contractor shall indemnify and save harmless the Board of Transportation and its members and the Department of Transportation and its officers, agents, and employees from all suits, actions, or claims of any character brought for any injury or damages received or sustained by any person, persons, or property by reason of any act of the Contractor, Subcontractor, its agents or employees, in the performance of the contract.

## **PAYMENT AND RETAINAGE**

The Contractor may submit requests for partial payments on a monthly basis, or other interval as approved by the Engineer. Compensation for all pay items shall be in accordance with the Standard Specifications. The amount of partial payments will be based on the work accomplished and accepted by the last day of the approved pay period.

Requests for payment shall be made by Contractor's Invoice. All invoice items and unit costs shall correspond to contract pay items. In the event of error or discrepancy in items or unit costs, the Department may return the invoice to the contractor for correction. The invoice shall be completely and legibly filled out with all appropriate information and shall be signed by an authorized representative of the Contractor.

All invoices shall be original and submitted to the Division Roadside Environmental Engineer for approval.

**Statements of all Subcontractor payments shall be included with invoices. These statements are to be submitted on the Subcontractor Payment Information Form (DBE-IS), they shall be original and in ink.**

**Payment will not be made until invoices and DBE-IS forms are received. Invoices should be received by the Department within 30 days of the completion of the work.**

All requests for payment shall be submitted to:

**Mr. Mark Thompson  
Division Roadside Environmental Engineer  
N.C. Department of Transportation  
121 DOT Drive (Mail and Delivery)  
Carthage, NC 28327  
[mcthompson1@ncdot.gov](mailto:mcthompson1@ncdot.gov) (Email)**

Due to the nature of the contract, no retainage will be withheld. However, the Department reserves the right to withhold payment for a specific location until after successful completion of the work as verified by the final inspection of that location.

All work or items, other than those listed on the Bid Form contained in the Contract Proposal, necessary to complete this work will be considered incidental in nature and no further compensation will be made.

Payment to the Contractor will be made only for the actual quantities of the various items that are completed and accepted in accordance with the terms of the contract. The advertised bid quantities are considered to be approximate only and are given as the basis for comparison of bids. The Department of Transportation may increase or decrease the quantity of any item or portion of the work as may be deemed necessary or expedient. Unless otherwise specified, all contract pay items will be produced, placed and paid in accordance with the

## **PROJECT SPECIAL PROVISIONS - ROADWAY**

### **LITTER/DEBRIS REMOVAL AND RECYCLING**

An abundance of non-organic trash in a multitude of forms is deposited daily along the roadsides of the designated highways. These conditions detract from the visual quality and/or safety of the roadside landscape.

This contract is for litter/debris removal and recycling on interstate, primary and secondary roads and their interchanges in Richmond and Montgomery Counties, and litter removal and recycling on secondary roads only in Randolph County within the State Maintained Highway System Right of Way in Division 8. All primary roads are designated for each litter cycle. All secondary roads will be assigned 15 days prior to the beginning of the cycle.

The routine work in this contract includes bi-monthly cleanups on all routes identified in the proposal documents under "Litter/Debris Removal and Recycling Plans" as well as on call cleanups on routes within a division.

All items include all traffic control necessary to provide a safe work area. The work shall include the furnishing of all equipment, tools, materials, transportation and labor necessary for the successful completion of the work.

No separate payment will be made for providing, installing, and maintaining traffic control devices, etc., or for any other cost associated with maintaining the control of traffic. Traffic control will be considered incidental to the contract and will be included in the Bid Items as listed on the Contract Bid Form.

The designated area for routine litter/debris removal and recycling is the entire corridor from controlled access fence to controlled access fence, or right of way width, including the median and interchange areas, to the travel lane, as directed by the Engineer, **except for along concrete barrier walls in medians. (Litter crew and vehicles are not allowed against median concrete barrier walls).** The designated area for on call litter/debris removal and recycling on shoulders is the white edge line to the back of the right of way on outside shoulders, which includes paved shoulders. The designated area for on call litter/debris removal and recycling in medians is from yellow edge line to yellow edge line, which includes paved shoulders, except for all concrete barrier walls. This includes the mowing areas as well as non-mowing areas.

The Contractor should be prepared for removing litter/debris in roadside conditions including but not limited to wet areas, standing water, high grass, and slopes. Contractor will not be responsible for removing litter/debris in wooded areas or back slopes unless litter is visible from the roadway and/or ramps.

The operation of litter/debris pickup shall be on foot only. Vehicles as specified herein may be used for bag pickup.

The Contractor must complete one (1) litter/debris pickup area prior to moving to the next (not to exceed over 5 miles).

The Contractor shall provide adequate personnel and materials (litterbags) to remove litter/debris on all areas of the right-of-way or controlled access.

The operation shall include the pickup, removal and recycling of litter/debris and the disposal of same into state approved landfills and single-stream recycling facilities. Litter/debris items may consist of varied sizes of bottles, cans, paper, tires, tire pieces, lumber, vehicle parts, building supplies, metals, household furnishings, cardboard, plastics, ladders, brush and other items not considered normal to the right of way.

The Contractor shall be responsible for locating and utilizing approved local landfills and recycling facilities so as not to impede the progress of the cleanup operation.

All collected litter/debris shall be containerized immediately and kept off of the traveled portions of the roadway, shoulders, and right-of-ways (including paved shoulders) during that day's collection process. All collected litter that is small enough to be placed in a bag shall be bagged immediately. All collected litter that is too large for a bag shall be placed into a vehicle. Uncollected storage or stockpiling of litter/debris and recyclables (piles of litterbags, tires, tire debris, etc.) will not be permitted. **At no time shall bags or collected litter/debris be allowed to remain on the right of way beyond the end of the work day.**

All cost involved with the disposal of the litter/debris shall be included in the contract unit price for "Litter/Debris Removal and Recycling". Vehicles for litter/debris removal activities shall at all times be parked off the pavement as close to the right-of-way fence as possible.

The Contractor's personnel shall pickup and dispose of any litter/debris, not required to be recycled, in a landfill approved by North Carolina Division of Waste Management. Litter/debris may consist of any item not considered

normal to the right-of-way. The Contractor will not be allowed to use NCDOT accounts at the landfills nor be allowed to dispose of the litter/debris in NCDOT trash containers on any NCDOT property.

The Contractor shall submit dumping ticket of the number of pounds of litter/debris not recycled to the Roadside Environmental Office with the Contractor's invoice. Clean up shall not be considered accepted by the Department until the original **DUMPING TICKET** issued to the Contractor for disposing the materials picked up during the assigned work is presented to the Department's inspector.

**This contract shall be immediately terminated if the contractor is found guilty of illegal dumping. Work will be suspended if contractor is charged with illegal dumping.**

The Contractor's attention is directed to North Carolina General Statute 130A-309.10 (f) though (m). Per this statute, the Contractor performing litter clean up and removal shall be required to recycle, including, but not limited to, aluminum cans, glass bottles, plastic bottles, and rubber tires collected within the right of way. In an effort to align with efforts by the Department to recycle with litter removal, the Contractor shall participate in single-stream recycling. The Contractor shall be responsible for locating and utilizing single-stream recycling facilities for disposal of recyclable litter/debris removed from the right of way as part of the work of this contract. The Contractor may recycle at any public or commercial recycling facility so long as the facility has the ability to provide weight tickets.

Assistance in locating recycling facilities may be obtained on the following websites:

<http://portal.ncdenr.org/web/deao/mrf>,  
<http://www.p2pays.org/dmrm/start.aspx>,  
<http://p2pays.org/localgov/ncwaste.html>.

The Contractor shall utilize blue bags, similar to those used by the Department, for the collection of recyclable materials. The Contractor will not be allowed to use NCDOT accounts at the recycling facilities nor be allowed to dispose of the litter/debris in NCDOT recycling containers on any NCDOT property.

The Contractor shall report the number of pounds of each of the recycled materials listed to the Roadside Environmental Office on, at a minimum, a monthly basis on the provided form in the section "Litter/Debris Removal and Recycling Plans". **The North Carolina Department of Transportation will require evidence of reported recycling using weight tickets from the recycling facilities.**

**If the Contractor is not fulfilling the intent of the Department to participate in a recycling program it could result in termination of this contract.**

**The Engineer reserves the right to schedule litter/debris removal and recycling operations so as not to conflict with mowing and/or vegetation management operations. Any bags, litter, or debris that are not removed before mowing and are shredded by the mowers must still be removed.**

**As directed, the removal of litter shall occur prior to mowing operations for all primary road systems and to the extent practical on secondary roads as stated in G.S. 136-28.12 (a).**

## **REPORTING**

The Contractor shall report online the amount of bags of litter/debris and recycling on the NCDOT Litter Management Website:

<https://apps.ncdot.gov/LM>

The Contractor is required to report all pickups on the date of the pickup. Payment for litter pickup invoiced will not be paid unless reported.

### **HAZARDOUS, CONTAMINATED, AND/OR TOXIC MATERIAL**

The Contractor's personnel shall not be responsible for removing hazardous materials from the right-of-ways, but shall notify an NCDOT representative as soon as possible.

When the Contractor's operations encounter or expose any abnormal condition which may indicate the presence of a hazardous, contaminated, and/or toxic material, such operations shall be discontinued in the vicinity of the abnormal condition and the Engineer shall be notified immediately.

The Contractor will not be responsible for the clean-up and removal of dead animals. If this situation is encountered, the Contractor shall contact the Engineer as directed.

### **MOBILIZATION**

For On Call Litter/Debris Removal and Recycling, the Contractor will be required to mobilize within the specified time frame as directed by the Engineer. Mobilization shall be considered incidental to the other bid items in this contract. No direct payment will be made for Mobilization.

The NCDOT will notify the Contractor of each location on the state highway system where litter collection and removal is required. Notification may be made by telephone or email and either method shall be considered sufficient. At the time of notification the Engineer shall inform the Contractor of the facility type so that the Contractor can plan their operations and work zone traffic control. **The Contractor** shall begin work within forty-eight (48) hours of notification and will be required to prosecute the work in a continuous and uninterrupted manner from the time he begins work until completion and final acceptance of the work in each notification All work shall be subject to inspection by the Engineer at any time.

### **SAFETY**

**Contractor performing Work Zone Traffic Control shall have a minimum of one (1) NCDOT Certified Work Zone Supervisor. At no time during the contract is the Contractor to be without a NCDOT Certified Work Zone Supervisor. The NCDOT Certified Work Zone Supervisor must be on site during any traffic control activities that take place within the travel lane or otherwise alter the flow of traffic.**

All stages of the litter/debris removal operation shall be accomplished in accordance with the "Work Zone Traffic Control Guidance for Litter/Debris Removal" in the Appendix. The NCDOT Certified Work Zone Supervisor shall submit traffic control plans for the approval of the Engineer, who may adjust or require additional control measures if warranted.

The Contractor will be held responsible for all damage or injury to property of any character resulting from any act, omission, negligence, or misconduct in the prosecution of the work. When any direct or indirect damage or injury is done to public or private property by or on account of any act, omission, negligence, or misconduct in the execution of the work, the Contractor shall either restore at his/her own expense such property to a condition similar or equal to that existing before such damage or injury was done, or shall make good such damage or injury in a manner acceptable to the owner of the damaged property and to the Department. In case of failure on the part of the Contractor to restore such property or make good such damage or injury the Department may at the Contractor's expense repair, rebuild, or otherwise restore such property in such manner, as the Engineer may consider necessary.

The Contractor's operations are restricted to daylight hours. Work shall only be performed when weather and visibility conditions allow safe operations.

## **EQUIPMENT REQUIREMENTS**

The Contractor shall furnish equipment of sufficient type, capacity, and quantity to safely and efficiently perform the litter/debris removal work. All vehicles used by the Contractor must be performance worthy by visual and operational inspection. The Contractor shall display and telephone number the company name on each piece of equipment. Side by side utility vehicles with beds capable of carrying litter bags with specified warning lights may be allowed for bag pickup only. Four wheeler vehicles will not be allowed.

All vehicles, including trailers, used in the removal operation should be properly equipped with lighting per Roadway Standard Drawing 1165.01 Sheet 1 of 1. Trailers shall have rear mounted strobe lights, mounted as high as possible to enhance visibility.

The Contractor shall furnish, mount, and maintain a W10-11 or W10-11A "DEBRIS PICK UP FREQUENT STOPS" sign on the rear of each vehicle or trailer such that they can be easily read by motorists approaching from the rear. Details of the sign is included in the "Work Zone Traffic Control Guidance for Litter/Debris Removal" of this proposal. The sign must not obstruct any safety lighting or the operator's view.

The Contractor shall be responsible for the equipment provided in this contract at all times and at all locations during the term of the contract. The Contractor shall have no claim against the Department of Transportation for any expense involving damage or loss to the Contractor's equipment (including vandalism, theft, fire and acts of God, etc.) arising out of, or relating to, work performed under this agreement.

**The safety of the public and the convenience of traffic shall be regarded as prime importance. The Contractor shall operate the equipment in a safe manner so as not to create a hazard to the traveling public. Crossing lanes of traffic and erratic driving will be strictly prohibited.**

Signs, lights, safety, and other traffic control items are not a pay item, but are considered incidental to other contract items and the Contractor is expected to provide these items.

### **EQUIPMENT IDLING GUIDELINES:**

(1-19-21)

107

SP1 G096

Exercise reduced fuel consumption and reduced equipment emissions during the construction of all work associated with this contract. Employees engaged in the construction of this project should turn off vehicles when stopped for more than thirty (30) minutes and off-highway equipment should idle no longer than fifteen (15) consecutive minutes.

These guidelines for turning off vehicles and equipment when idling do not apply to:

1. Idling when queuing.
2. Idling to verify the vehicle is in safe operating condition.
3. Idling for testing, servicing, repairing or diagnostic purposes.
4. Idling necessary to accomplish work for which the vehicle was designed (such as operating a crane, mixing concrete, etc.).
5. Idling required to bring the machine system to operating temperature.
6. Emergency vehicles, utility company, construction, and maintenance vehicles where the engines must run to perform needed work.
7. Idling to ensure safe operation of the vehicle.
8. Idling when the propulsion engine is providing auxiliary power for other than heating or air conditioning. (such as hydraulic systems for pavers)
9. When specific traffic, safety, or emergency situations arise.
10. If the ambient temperature is less than 32 degrees Fahrenheit. Limited idling to provide for the safety of vehicle occupants (e.g. to run the heater).

11. If the ambient temperature is greater than 90 degrees Fahrenheit. Limited idling to provide for the safety of vehicle occupants of off-highway equipment (e.g. to run the air conditioning) no more than 30 minutes.
12. Diesel powered vehicles may idle for up to 30 minutes to minimize restart problems.

Any vehicle, truck, or equipment in which the primary source of fuel is natural gas or electricity is exempt from the idling limitations set forth in this special provision.

### **DELETION OF SECTIONS**

In the event that a road rehabilitation or improvement project is under construction or will be under construction where litter/debris removal and recycling is scheduled, that section of road may be deleted from the appropriate list at the direction of the Department. The section may be re-inserted in the list following completion of the road rehabilitation or improving project.

In the event that the litter removal (complete corridor or outside shoulder only) for sections of road becomes a part of either the Adopt-A-Highway or Sponsor-A-Highway Program, those sections of road may be deleted from the appropriate list at the direction of the Department in compliance with Section 104-6 of the Standard Specifications. Additional compensation as provided in Section 104-5 of the Standard Specifications does not apply. The section may be re-inserted in the list at the direction of the Department.

It is understood that during the course of the contract, portions of the routes may be deleted from the contract (due to construction projects, Adopt-A-Highway, Sponsor-A-Highway Program, etc.). It will be the responsibility of the Contractor to clean or not clean such sections as directed by the Engineer.

### **BID ITEMS**

This contract will consist of the following six (6) pay items:

**NOTE: Miles shown in the provided spreadsheets are based on centerline length of the corridor.**

1. **Routine Litter/Debris Removal and Recycling on Interstate Highways per Mile:** This item will account for the cycles of litter/debris removal and recycling on divided highways. This work shall be performed monthly per route as identified in the provided spreadsheet.
2. **Routine Litter/Debris Removal and Recycling on Primary Divided Highways per Mile:** This item will account for the cycles of litter/debris removal and recycling on divided highways. This work shall be performed bi-monthly per route as identified in the provided spreadsheet.
3. **Routine Litter/Debris Removal and Recycling on Primary Undivided Highways per Mile:** This item will account for the cycles of litter/debris removal and recycling on undivided highways. This work shall be performed bi-monthly per route as identified in the provided spreadsheet.
4. **Routine Litter/Debris Removal and Recycling on Secondary Undivided Highways per Mile:** This item will account for the cycles of litter/debris removal and recycling on undivided highways. This work shall be performed bi-monthly per route as identified in the provided spreadsheet.
5. **On Call Litter/Debris Removal and Recycling, Outside Shoulder per Shoulder Mile:** This item will account for outside shoulder clean up on routes not included in the routine litter/debris removal and recycling cycle; or for additional litter/debris removal and recycling beyond the bi-monthly cycle for routes included in the routine litter/debris removal and recycling.
6. **On Call Litter/Debris Removal and Recycling, Median per Mile:** This item will account for median litter/debris removal and recycling (yellow edge line to yellow edge line) on routes not included in the



routine litter/debris removal and recycling; or for additional litter/debris removal and recycling beyond the bi-monthly cycle for routes included in the routine litter/debris removal and recycling.

### **QUALITY, INSPECTION AND BASIS OF ACCEPTANCE**

It is intended that the work will be completed in a neat, continuous, and uninterrupted manner as determined by the Engineer. Completed work shall be clean and free of all accumulated litter/debris immediately after litter/debris removal and recycling. All work shall be subject to inspection by the Engineer at any time. The Engineer or a designated representative will make periodic next day inspections of the completed work. **It will be the responsibility of the Contractor to keep the Engineer informed of his/her proposed work plan by submitting weekly reports of work accomplished and of planned work for the upcoming week. The Contractor shall notify the NCDOT by email when litter collection and trash bag removal is completed.**

The Department of Transportation will verify completion of the Contractor's work on a monthly basis before payment of invoice.

### **METHOD OF MEASUREMENT**

The quantity of Routine Litter/Debris Removal and Recycling on Interstate Highways per Mile will be based on the corridor miles completed (mileage based on theoretical values as shown on provided spreadsheets). Normally, one map mile of multi-lane divided highways, including median, shall equal one (1) mile. **Quantities will be measured to the nearest (0.1) tenth of a mile measured along the centerline of the roadway.**

The quantity of Routine Litter/Debris Removal and Recycling on Primary Divided Highways per Mile will be based on the corridor miles completed (mileage based on theoretical values as shown on provided spreadsheets). Normally, one map mile of multi-lane divided highways, including median, shall equal one (1) mile. **Quantities will be measured to the nearest (0.1) tenth of a mile measured along the centerline of the roadway.**

The quantity of Routine Litter/Debris Removal and Recycling on Primary Undivided Highways per Mile will be based on the corridor miles completed (mileage based on theoretical values as shown on provided spreadsheets). Normally, one map mile of undivided highways shall equal one (1) mile. **Quantities will be measured to the nearest (0.1) tenth of a mile measured along the centerline of the roadway.**

The quantity of Routine Litter/Debris Removal and Recycling on Secondary Undivided Highways per Mile will be based on the corridor miles completed (mileage based on theoretical values as shown on provided spreadsheets). Normally, one map mile of undivided highways shall equal one (1) mile. **Quantities will be measured to the nearest (0.1) tenth of a mile measured along the centerline of the roadway.**

The quantity of On Call Litter/Debris Removal and Recycling, Outside Shoulder per Mile will be based on the actual number of shoulder miles completed. For outside shoulder litter/debris removal and recycling only, one map mile shall equal two (2) shoulder miles. Shoulder miles shall be measured along the edge of pavement adjacent to the area where successful litter/debris removal and recycling has been performed.

The quantity of On Call Litter/Debris Removal and Recycling, Median per Mile will be based on the actual number of median shoulder miles completed. For median litter/debris removal and recycling only, one map mile shall equal one (1) mile. **(Litter crew and vehicles are not allowed against median concrete barrier walls).**

Highway mileage will be determined from NCDOT county maintenance maps. In the case of dispute or obvious error, the mileage shall be measured by a representative of the North Carolina Department of Transportation and the Contractor.

**BASIS OF PAYMENT**

The quantity of Routine Litter/Debris Removal and Recycling on Interstate Highways, measured as provided above, will be paid for at the Mile price for “Routine Litter/Debris Removal and Recycling on Divided Highways”.

The quantity of Routine Litter/Debris Removal and Recycling on Primary Divided Highways, measured as provided above, will be paid for at the Mile price for “Routine Litter/Debris Removal and Recycling on Divided Highways”.

The quantity of Routine Litter/Debris Removal and Recycling on Primary Undivided Highways, measured as provided above, will be paid for at the Mile price for “Routine Litter/Debris Removal and Recycling on Undivided Highways”.

The quantity of Routine Litter/Debris Removal and Recycling on Secondary Undivided Highways, measured as provided above, will be paid for at the Mile price for “Routine Litter/Debris Removal and Recycling on Undivided Highways”.

The quantity of On Call Litter/Debris Removal and Recycling, Outside Shoulder, measured as provided above, will be paid for at the Shoulder Mile price for “On Call Litter/Debris Removal and Recycling, Outside Shoulder”.

The quantity of On Call Litter/Debris Removal and Recycling, Median, measured as provided above, will be paid for at the Mile price for “On Call Litter/Debris Removal and Recycling, Median”.

Bid prices and payments will be full compensation for all work, including but not limited to supervision, labor, transportation, fuels, lubricants, repair parts, equipment, machinery, tools, and dumping fees, necessary for the prosecution and completion of the work. Payments will be made to the Contractor for work accomplished and accepted.

Payment for these items will be made for as follows:

- Routine Litter/Debris Removal and Recycling on Interstate Highways..... **MI**
- Routine Litter/Debris Removal and Recycling on Primary Divided Highways ..... **MI**
- Routine Litter/Debris Removal and Recycling on Primary Undivided Highways..... **MI**
- Routine Litter/Debris Removal and Recycling on Secondary Undivided Highways.... **MI**
- On Call Litter/Debris Removal and Recycling, Outside Shoulder..... **SMI**
- On Call Litter/Debris Removal and Recycling, Median..... **MI**

## STANDARD SPECIAL PROVISIONS

### AVAILABILITY OF FUNDS – TERMINATION OF CONTRACTS

(5-20-08)

Z-2

*General Statute 143C-6-11. (h) Highway Appropriation* is hereby incorporated verbatim in this contract as follows:

(h) Amounts Encumbered. – Transportation project appropriations may be encumbered in the amount of allotments made to the Department of Transportation by the Director for the estimated payments for transportation project contract work to be performed in the appropriation fiscal year. The allotments shall be multiyear allotments and shall be based on estimated revenues and shall be subject to the maximum contract authority contained in *General Statute 143C-6-11(c)*. Payment for transportation project work performed pursuant to contract in any fiscal year other than the current fiscal year is subject to appropriations by the General Assembly. Transportation project contracts shall contain a schedule of estimated completion progress, and any acceleration of this progress shall be subject to the approval of the Department of Transportation provided funds are available. The State reserves the right to terminate or suspend any transportation project contract, and any transportation project contract shall be so terminated or suspended if funds will not be available for payment of the work to be performed during that fiscal year pursuant to the contract. In the event of termination of any contract, the contractor shall be given a written notice of termination at least 60 days before completion of scheduled work for which funds are available. In the event of termination, the contractor shall be paid for the work already performed in accordance with the contract specifications.

Payment will be made on any contract terminated pursuant to the special provision in accordance with Subarticle 108-13(E) of the *2018 Standard Specifications*.

### AUTHORITY OF THE ENGINEER

The Engineer for this project shall be the Division Engineer, Division of Highways, North Carolina Department of Transportation, for the Division in which the project is located, acting directly for through his duly authorized representatives.

The Engineer will decide all questions which may arise as to the quality and acceptability of work performed and as to the rate of progress of the work; all questions which may arise as to the interpretation of the contract; and all questions as to the acceptable fulfillment of the contract on the part of the contractor. He shall have the authority to alter priorities in order to address special needs of the Department. His decision shall be final and he shall have executive authority to enforce and make effective such decisions and orders as the Contractor fail to carry out promptly.

### MINIMUM WAGES

(7-21-09)

Z-5

**FEDERAL:** The Fair Labor Standards Act provides that with certain exceptions every employer shall pay wages at the rate of not less than SEVEN DOLLARS AND TWENTY FIVE CENTS (\$7.25) per hour.

**STATE:** The North Carolina Minimum Wage Act provides that every employer shall pay to each of his employees, wages at a rate of not less than SEVEN DOLLARS AND TWENTY FIVE CENTS (\$7.25) per hour.

The minimum wage paid to all skilled labor employed on this contract shall be SEVEN DOLLARS AND TWENTY FIVE CENTS (\$7.25) per hour.

The minimum wage paid to all intermediate labor employed on this contract shall be SEVEN DOLLARS AND TWENTY FIVE CENTS (\$7.25) per hour.

The minimum wage paid to all unskilled labor on this contract shall be SEVEN DOLLARS AND TWENTY FIVE CENTS (\$7.25) per hour.

This determination of the intent of the application of this act to the contract on this project is the responsibility of the Contractor.

The Contractor shall have no claim against the Department of Transportation for any changes in the minimum wage laws, Federal or State. It is the responsibility of the Contractor to keep fully informed of all Federal and State Laws affecting his contract.

### **EROSION CONTROL**

The Contractor shall exercise every reasonable precaution throughout the life of the project to prevent erosion and siltation.

### **WORK ZONE SIGNING**

(10-21-08)

RWZ-3

#### **Description**

Install and maintain signing in accordance with Divisions 11 and 12 of the *Standard Specifications*, the *Roadway Standard Drawings* and the following provisions:

The Contractor shall be responsible for all signs and signing.

### **PLANT AND PEST QUARANTINES**

**(Imported Fire Ant, Gypsy Moth, Witchweed, Emerald Ash Borer, Guava Root Knot Nematode, And Other Noxious Weeds)**

(3-18-03) (Rev. 5-21-19)

Z-04a

#### **Within Quarantined Area**

This project may be within a county regulated for plant and/or pests. If the project or any part of the Contractor's operations is located within a quarantined area, thoroughly clean all equipment prior to moving out of the quarantined area. Comply with federal/state regulations by obtaining a certificate or limited permit for any regulated article moving from the quarantined area.

#### **Originating in a Quarantined County**

Obtain a certificate or limited permit issued by the N.C. Department of Agriculture/United States Department of Agriculture. Have the certificate or limited permit accompany the article when it arrives at the project site.

#### **Contact**

Contact the N.C. Department of Agriculture/United States Department of Agriculture at 1-800-206-9333, 919-707-3730, or <https://www.ncagr.gov/plantindustry/Plant/quaran/table2.htm> to determine those specific project sites located in the quarantined area or for any regulated article used on this project originating in a quarantined county.

#### **Regulated Articles Include**

1. Soil, sand, gravel, compost, peat, humus, muck, and decomposed manure, separately or with other articles. This includes movement of articles listed above that may be associated with cut/waste, ditch pulling, and shoulder cutting.
2. Plants with roots including grass sod.
3. Plant crowns and roots.

4. Bulbs, corms, rhizomes, and tubers of ornamental plants.
5. Hay, straw, fodder, and plant litter of any kind.
6. Clearing and grubbing debris.
7. Used agricultural cultivating and harvesting equipment.
8. Used earth-moving equipment.
9. Any other products, articles, or means of conveyance, of any character, if determined by an inspector to present a hazard of spreading imported fire ant, gypsy moth, witchweed, emerald ash borer, guava root knot nematode, or other noxious weeds.

#### **BANKRUPTCY**

The Department of Transportation, at its option, may terminate the contract upon filing by the Contractor of any petition for protection under the provisions of the Federal Bankruptcy Act.

#### **SUBLETTING OF CONTRACT**

If a Contractor desires to sublet any work, written consent must be given by the Engineer. The approval of any subcontract will not release the Contractor of liability under the contract, nor will the subcontractor or the second tier subcontractor have any claim against NCDOT by reason of the approval of the subcontract.

#### **DEBARMENT STATEMENT**

The Contractor certifies and understands that by his/her signature on the Bid Form that he/she and the contracting firm he/she represents has not been banned, debarred, suspended, proposed for debarment, or declared ineligible for the award of contracts by any Federal agency.

#### **DEFAULT OF CONTRACT**

The Department of Transportation shall have the right to declare a default of contract for breach by the Contractor of any material term or condition of the contract. Default of contract shall be in accordance with the terms, conditions, and procedures of Article 108-9 of the Standard Specifications.

#### **COOPERATION BETWEEN CONTRACTORS**

The Department reserves the right at any time to contract for and perform other or additional work on or near the work covered by the contract. When separate or additional contracts are let within the limits of any one project, each Contractor shall conduct his work so as not to interfere with or hinder the progress or completion of the work being performed by other Contractors. Contractors working within the limits of the same project shall cooperate with each other. Each Contractor shall conduct his operations in such a manner as to avoid damaging any work being performed by others or which others have completed.

#### **NO MAJOR CONTRACT ITEMS**

None of the items included in this contract will be major items.

#### **NO SPECIALTY ITEMS**

None of the items included in this contract will be specialty items (see Article 108-6 of the *2018 Standard Specifications*).

## **UTILITY CONFLICTS**

Special care shall be used in working around or near existing utilities, protecting them when necessary to provide uninterrupted service. In the event that any utility service is interrupted, the Contractor shall notify the utility owner immediately and shall cooperate with the owner, or his representative, in the restoration of service in the shortest time possible. Existing fire hydrants shall be kept accessible to fire departments at all times.

The Contractor shall adhere to all applicable regulations and follow accepted safety procedures when working in the vicinity of utilities in order to insure the safety of construction personnel and the public.

## **DRIVEWAYS AND PRIVATE PROPERTY**

The Contractor shall maintain access to driveways for all residents, businesses, and property owners throughout the life of the project. The Contractor shall not perform work for private citizens or agencies in conjunction with this project or within the project limits of this contract.

## **OUTSOURCING OUTSIDE THE USA**

All work on consultant contracts, services contracts, and construction contracts shall be performed in the United States of America. No work shall be outsourced outside of the United States of America.

*Outsourcing* for the purpose of this provision is defined as the practice of subcontracting labor, work, services, staffing, or personnel to entities located outside of the United States.

The North Carolina Secretary of Transportation shall approve exceptions to this provision in writing.

## **TITLE VI AND NONDISCRIMINATION**

Revise the *2018 Standard Specifications* as follows:

Replace Article 103-4(B) with the following:

The North Carolina Department of Transportation is committed to carrying out the U.S. Department of Transportation's policy of ensuring nondiscrimination in the award and administration of contracts.

The provisions of this section related to United States Department of Transportation (US DOT) Order 1050.2A, Title 49 Code of Federal Regulations (CFR) part 21, 23 United States Code (U.S.C.) 140 and 23 CFR part 200 (or 49 CFR 303, 49 U.S.C. 5332 or 49 U.S.C. 47123) are applicable to all North Carolina Department of Transportation (NCDOT) contracts and to all related subcontracts, material supply, engineering, architectural and other service contracts, regardless of dollar amount. Any Federal provision that is specifically required not specifically set forth is hereby incorporated by reference.

### **(1) Title VI Assurances (USDOT Order 1050.2A, Appendix A)**

During the performance of this contract, the contractor, for itself, its assignees, and successors in interest (hereinafter referred to as the "contractor") agrees as follows:

#### **(a) Compliance with Regulations**

The contractor (hereinafter includes consultants) shall comply with the Acts and the Regulations relative to Nondiscrimination in Federally-assisted programs of the U.S. Department of Transportation, Federal Highway Administration (FHWA), as they may be amended from time to time, which are herein incorporated by reference and made a part of this contract.

#### **(b) Nondiscrimination**

The contractor, with regard to the work performed by it during the contract, shall not discriminate on the grounds of race, color, or national origin in the selection and retention of subcontractors, including procurements of materials and leases of equipment. The contractor shall not participate directly or

indirectly in the discrimination prohibited by the Acts and the Regulations, including employment practices when the contract covers any activity, project, or program set forth in Appendix B of 49 CFR Part 21.

(c) **Solicitations for Subcontractors, Including Procurements of Materials and Equipment**

In all solicitations, either by competitive bidding, or negotiation made by the contractor for work to be performed under a subcontract, including procurements of materials, or leases of equipment, each potential subcontractor or supplier shall be notified by the contractor of the contractor's obligations under this contract and the Acts and the Regulations relative to Nondiscrimination on the grounds of race, color, or national origin.

(d) **Information and Reports**

The contractor shall provide all information and reports required by the Acts, the Regulations, and directives issued pursuant thereto and shall permit access to its books, records, accounts, other sources of information, and its facilities as may be determined by the Recipient or the FHWA to be pertinent to ascertain compliance with such Acts, Regulations, and instructions. Where any information required of a contractor is in the exclusive possession of another who fails or refuses to furnish the information, the contractor shall so certify to the Recipient or the FHWA, as appropriate, and shall set forth what efforts it has made to obtain the information.

(e) **Sanctions for Noncompliance:**

In the event of a contractor's noncompliance with the Non-discrimination provisions of this contract, the Recipient will impose such contract sanctions as it and/or the FHWA may determine to be appropriate, including, but not limited to:

- (i) Withholding payments to the contractor under the contract until the contractor complies; and/or
- (ii) Cancelling, terminating, or suspending a contract, in whole or in part.

(f) **Incorporation of Provisions**

The contractor shall include the provisions of paragraphs one through six in every subcontract, including procurements of materials and leases of equipment, unless exempt by the Acts, the Regulations and directives issued pursuant thereto. The contractor shall take action with respect to any subcontract or procurement as the Recipient or the FHWA may direct as a means of enforcing such provisions including sanctions for noncompliance. Provided, that if the contractor becomes involved in, or is threatened with litigation by a subcontractor, or supplier because of such direction, the contractor may request the Recipient to enter into any litigation to protect the interests of the Recipient. In addition, the contractor may request the United States to enter into the litigation to protect the interests of the United States.

**(2) Title VI Nondiscrimination Program (23 CFR 200.5(p))**

The North Carolina Department of Transportation (NCDOT) has assured the USDOT that, as a condition to receiving federal financial assistance, NCDOT will comply with Title VI of the Civil Rights Act of 1964 and all requirements imposed by Title 49 CFR part 21 and related nondiscrimination authorities to ensure that no person shall, on the ground of race, color, national origin, limited English proficiency, sex, age, or disability (including religion/creed or income-level, where applicable), be excluded from participation in, be denied the benefits of, or be subjected to discrimination under any programs, activities, or services conducted or funded by NCDOT. Contractors and other organizations under contract or agreement with NCDOT must also comply with Title VI and related authorities, therefore:

- (a) During the performance of this contract or agreement, contractors (e.g., subcontractors, consultants, vendors, prime contractors) are responsible for complying with NCDOT's Title VI Program. Contractors are not required to prepare or submit Title VI Programs. To comply with this section, the prime contractor shall:
1. Post NCDOT's Notice of Nondiscrimination and the Contractor's own Equal Employment Opportunity (EEO) Policy in conspicuous locations accessible to all employees, applicants and subcontractors on the jobsite.
  2. Physically incorporate the required Title VI clauses into all subcontracts on federally-assisted and state-funded NCDOT projects, and ensure inclusion by subcontractors into all lower-tier subcontracts.
  3. Required Solicitation Language. The Contractor shall include the following notification in all solicitations for bids and requests for work or material, regardless of funding source:  
"The North Carolina Department of Transportation, in accordance with the provisions of Title VI of the Civil Rights Act of 1964 (78 Stat. 252, 42 U.S.C. §§ 2000d to 2000d-4) and the Regulations, hereby notifies all bidders that it will affirmatively ensure that any contract entered into pursuant to this

advertisement, disadvantaged business enterprises will be afforded full and fair opportunity to submit bids in response to this invitation and will not be discriminated against on the grounds of race, color, or national origin in consideration for an award. In accordance with other related nondiscrimination authorities, bidders and contractors will also not be discriminated against on the grounds of sex, age, disability, low-income level, creed/religion, or limited English proficiency in consideration for an award.”

4. Physically incorporate the FHWA-1273, in its entirety, into all subcontracts and subsequent lower tier subcontracts on Federal-aid highway construction contracts only.
  5. Provide language assistance services (i.e., written translation and oral interpretation), free of charge, to LEP employees and applicants. Contact NCDOT OCR for further assistance, if needed.
  6. For assistance with these Title VI requirements, contact the NCDOT Title VI Nondiscrimination Program at 1-800-522-0453.
- (b) Subrecipients (e.g. cities, counties, LGAs, planning organizations) may be required to prepare and submit a Title VI Plan to NCDOT, including Title VI Assurances and/or agreements. Subrecipients must also ensure compliance by their contractors and subrecipients with Title VI. (23 CFR 200.9(b)(7))
- (c) If reviewed or investigated by NCDOT, the contractor or subrecipient agrees to take affirmative action to correct any deficiencies found within a reasonable time period, not to exceed 90 calendar days, unless additional time is granted by NCDOT. (23 CFR 200.9(b)(15))
- (d) The Contractor is responsible for notifying subcontractors of NCDOT’s External Discrimination Complaints Process.
1. Applicability  
Title VI and related laws protect participants and beneficiaries (e.g., members of the public and contractors) from discrimination by NCDOT employees, subrecipients and contractors, regardless of funding source.
  2. Eligibility  
Any person—or class of persons—who believes he/she has been subjected to discrimination based on race, color, national origin, Limited English Proficiency (LEP), sex, age, or disability (and religion in the context of employment, aviation, or transit) may file a written complaint. The law also prohibits intimidation or retaliation of any sort.
  3. Time Limits and Filing Options  
Complaints may be filed by the affected individual(s) or a representative and must be filed no later than 180 calendar days after the following:
    - (i) The date of the alleged act of discrimination; or
    - (ii) The date when the person(s) became aware of the alleged discrimination; or
    - (iii) Where there has been a continuing course of conduct, the date on which that conduct was discontinued or the latest instance of the conduct.
 Title VI and related discrimination complaints may be submitted to the following entities:
    - North Carolina Department of Transportation, Office of Civil Rights, Title VI Program, 1511 Mail Service Center, Raleigh, NC 27699-1511; toll free 1-800-522-0453
    - Federal Highway Administration, North Carolina Division Office, 310 New Bern Avenue, Suite 410, Raleigh, NC 27601, 919-747-7010
    - US Department of Transportation, Departmental Office of Civil Rights, External Civil Rights Programs Division, 1200 New Jersey Avenue, SE, Washington, DC 20590; 202-366-4070
  4. Format for Complaints  
Complaints must be in writing and signed by the complainant(s) or a representative, and include the complainant’s name, address, and telephone number. Complaints received by fax or e-mail will be acknowledged and processed. Allegations received by telephone will be reduced to writing and provided to the complainant for confirmation or revision before processing. Complaints will be accepted in other languages, including Braille.
  5. Discrimination Complaint Form  
Contact NCDOT Civil Rights to receive a full copy of the Discrimination Complaint Form and procedures.
  6. Complaint Basis



Allegations must be based on issues involving race, color, national origin (LEP), sex, age, disability, or religion (in the context of employment, aviation or transit). “Basis” refers to the complainant’s membership in a protected group category.

<b>TABLE 103-1 COMPLAINT BASIS</b>			
<b>Protected Categories</b>	<b>Definition</b>	<b>Examples</b>	<b>Applicable Nondiscrimination Authorities</b>
Race and Ethnicity	An individual belonging to one of the accepted racial groups; or the perception, based usually on physical characteristics that a person is a member of a racial group	Black/African American, Hispanic/Latino, Asian, American Indian/Alaska Native, Native Hawaiian/Pacific Islander, White	Title VI of the Civil Rights Act of 1964; 49 CFR Part 21; 23 CFR 200; 49 U.S.C. 5332(b); 49 U.S.C. 47123. <i>(Executive Order 13166)</i>
Color	Color of skin, including shade of skin within a racial group	Black, White, brown, yellow, etc.	
National Origin <i>(Limited English Proficiency)</i>	Place of birth. Citizenship is not a factor. <i>(Discrimination based on language or a person’s accent is also covered)</i>	Mexican, Cuban, Japanese, Vietnamese, Chinese	
Sex	Gender. The sex of an individual. <i>Note: Sex under this program does not include sexual orientation.</i>	Women and Men	1973 Federal-Aid Highway Act; 49 U.S.C. 5332(b); 49 U.S.C. 47123.
Age	Persons of any age	21-year-old person	Age Discrimination Act of 1975 49 U.S.C. 5332(b); 49 U.S.C. 47123.
Disability	Physical or mental impairment, permanent or temporary, or perceived.	Blind, alcoholic, para-amputee, epileptic, diabetic, arthritic	Section 504 of the Rehabilitation Act of 1973; Americans with Disabilities Act of 1990
Religion (in the context of employment) <i>(Religion/ Creed in all aspects of any aviation or transit-related construction)</i>	An individual belonging to a religious group; or the perception, based on distinguishable characteristics that a person is a member of a religious group. In practice, actions taken as a result of the moral and ethical beliefs as to what is right and wrong, which are sincerely held with the strength of traditional religious views. <i>Note: Does not have to be associated with a recognized religious group or church; if an individual sincerely holds to the belief, it is a protected religious practice.</i>	Muslim, Christian, Sikh, Hindu, etc.	Title VII of the Civil Rights Act of 1964; 23 CFR 230; FHWA-1273 Required Contract Provisions. <i>(49 U.S.C. 5332(b); 49 U.S.C. 47123)</i>

**(3) Pertinent Nondiscrimination Authorities**

During the performance of this contract, the contractor, for itself, its assignees, and successors in interest agrees to comply with the following non-discrimination statutes and authorities, including, but not limited to:

- Title VI of the Civil Rights Act of 1964 (42 U.S.C. § 2000d et seq., 78 stat. 252), (prohibits discrimination on the basis of race, color, national origin); and 49 CFR Part 21.

- The Uniform Relocation Assistance and Real Property Acquisition Policies Act of 1970, (42 U.S.C. § 4601), (prohibits unfair treatment of persons displaced or whose property has been acquired because of Federal or Federal-aid programs and projects);
- Federal-Aid Highway Act of 1973, (23 U.S.C. § 324 et seq.), (prohibits discrimination on the basis of sex);
- Section 504 of the Rehabilitation Act of 1973, (29 U.S.C. § 794 et seq.), as amended, (prohibits discrimination on the basis of disability) and 49 CFR Part 27;
- The Age Discrimination Act of 1975, as amended, (42 U.S.C. § 6101 et seq.), (prohibits discrimination on the basis of age);
- Airport and Airway Improvement Act of 1982, (49 USC § 471, Section 47123), as amended, (prohibits discrimination based on race, creed, color, national origin, or sex);
- (g) The Civil Rights Restoration Act of 1987, (PL 100-209), (Broadened the scope, coverage and applicability of Title VI of the Civil Rights Act of 1964, The Age Discrimination Act of 1975 and Section 504 of the Rehabilitation Act of 1973, by expanding the definition of the terms "programs or activities" to include all of the programs or activities of the Federal-aid recipients, sub-recipients and contractors, whether such programs or activities are Federally funded or not);
- (h) Titles II and III of the Americans with Disabilities Act, which prohibit discrimination on the basis of disability in the operation of public entities, public and private transportation systems, places of public accommodation, and certain testing entities (42 U.S.C. §§ 12131-12189) as implemented by Department of Transportation regulations at 49 C.F.R. parts 37 and 38;
- (i) The Federal Aviation Administration's Nondiscrimination statute (49 U.S.C. § 47123) (prohibits discrimination on the basis of race, color, national origin, and sex);
- (j) Executive Order 12898, Federal Actions to Address Environmental Justice in Minority Populations and Low-Income Populations, which ensures Nondiscrimination against minority populations by discouraging programs, policies, and activities with disproportionately high and adverse human health or environmental effects on minority and low-income populations;
- (k) Executive Order 13166, Improving Access to Services for Persons with Limited English Proficiency, and resulting agency guidance, national origin discrimination includes discrimination because of Limited English proficiency (LEP). To ensure compliance with Title VI, you must take reasonable steps to ensure that LEP persons have meaningful access to your programs (70 Fed. Reg. at 74087 to 74100);
- (l) Title IX of the Education Amendments of 1972, as amended, which prohibits you from discriminating because of sex in education programs or activities (20 U.S.C. 1681 et seq).
- (m) Title VII of the Civil Rights Act of 1964 (42 U.S.C. § 2000e et seq., Pub. L. 88-352), (prohibits employment discrimination on the basis of race, color, religion, sex, or national origin).

**(4) Additional Title VI Assurances**

*\*\*The following Title VI Assurances (Appendices B, C and D) shall apply, as applicable*

**(a) Clauses for Deeds Transferring United States Property (1050.2A, Appendix B)**

The following clauses will be included in deeds effecting or recording the transfer of real property, structures, or improvements thereon, or granting interest therein from the United States pursuant to the provisions of Assurance 4.

NOW, THEREFORE, the U.S. Department of Transportation as authorized by law and upon the condition that the North Carolina Department of Transportation (NCDOT) will accept title to the lands and maintain the project constructed thereon in accordance with the North Carolina General Assembly, the Regulations for the Administration of the Federal-Aid Highway Program, and the policies and procedures prescribed by the Federal Highway Administration of the U.S. Department of Transportation in accordance and in compliance with all requirements imposed by Title 49, Code of Federal Regulations, U.S. Department of Transportation, Subtitle A, Office of the Secretary, Part 21, Nondiscrimination in Federally-assisted programs of the U.S Department of Transportation pertaining to and effectuating the provisions of Title VI of the Civil Rights Act of 1964 (78 Stat. 252; 42 U.S.C. § 2000d to 2000d-4), does hereby remise, release, quitclaim and convey unto the NCDOT all the right, title and interest of the U.S. Department of Transportation in and to said lands described in Exhibit A attached hereto and made a part hereof.

(HABENDUM CLAUSE)

TO HAVE AND TO HOLD said lands and interests therein unto the North Carolina Department of Transportation (NCDOT) and its successors forever, subject, however, to the covenants, conditions, restrictions and reservations herein contained as follows, which will remain in effect for the period during which the real property or structures are used for a purpose for which Federal financial assistance is extended or for another purpose involving the provision of similar services or benefits and will be binding on the NCDOT, its successors and assigns.

The NCDOT, in consideration of the conveyance of said lands and interests in lands, does hereby covenant and agree as a covenant running with the land for itself, its successors and assigns, that (1) no person will on the grounds of race, color, or national origin, be excluded from participation in, be denied the benefits of, or be otherwise subjected to discrimination with regard to any facility located wholly or in part on, over, or under such lands hereby conveyed [,] [and]\* (2) that the NCDOT will use the lands and interests in lands and interests in lands so conveyed, in compliance with all requirements imposed by or pursuant to Title 49, Code of Federal Regulations, U.S. Department of Transportation, Subtitle A, Office of the Secretary, Part 21, Non-discrimination in Federally-assisted programs of the U.S. Department of Transportation, Effectuation of Title VI of the Civil Rights Act of 1964, and as said Regulations and Acts may be amended [, and (3) that in the event of breach of any of the above-mentioned nondiscrimination conditions, the Department will have a right to enter or re-enter said lands and facilities on said land, and that above described land and facilities will thereon revert to and vest in and become the absolute property of the U.S. Department of Transportation and its assigns as such interest existed prior to this instruction].\*

(\*Reverter clause and related language to be used only when it is determined that such a clause is necessary in order to make clear the purpose of Title VI.)

(b) Clauses for Transfer of Real Property Acquired or Improved Under the Activity, Facility, or Program (1050.2A, Appendix C)

The following clauses will be included in deeds, licenses, leases, permits, or similar instruments entered into by the North Carolina Department of Transportation (NCDOT) pursuant to the provisions of Assurance 7(a):

1. The (grantee, lessee, permittee, etc. as appropriate) for himself/herself, his/her heirs, personal representatives, successors in interest, and assigns, as a part of the consideration hereof, does hereby covenant and agree [in the case of deeds and leases add "as a covenant running with the land"] that:
  - (i.) In the event facilities are constructed, maintained, or otherwise operated on the property described in this (deed, license, lease, permit, etc.) for a purpose for which a U.S. Department of Transportation activity, facility, or program is extended or for another purpose involving the provision of similar services or benefits, the (grantee, licensee, lessee, permittee, etc.) will maintain and operate such facilities and services in compliance with all requirements imposed by the Acts and Regulations (as may be amended) such that no person on the grounds of race, color, or national origin, will be excluded from participation in, denied the benefits of, or be otherwise subjected to discrimination in the use of said facilities.
2. With respect to licenses, leases, permits, etc., in the event of breach of any of the above Nondiscrimination covenants, the NCDOT will have the right to terminate the (lease, license, permit, etc.) and to enter, re-enter, and repossess said lands and facilities thereon, and hold the same as if the (lease, license, permit, etc.) had never been made or issued. \*
3. With respect to a deed, in the event of breach of any of the above Nondiscrimination covenants, the NCDOT will have the right to enter or re-enter the lands and facilities thereon, and the above described lands and facilities will there upon revert to and vest in and become the absolute property of the NCDOT and its assigns. \*

(\*Reverter clause and related language to be used only when it is determined that such a clause is necessary to make clear the purpose of Title VI.)

(c) Clauses for Construction/Use/Access to Real Property Acquired Under the Activity, Facility or Program (1050.2A, Appendix D)

The following clauses will be included in deeds, licenses, permits, or similar instruments/ agreements entered into by the North Carolina Department of Transportation (NCDOT) pursuant to the provisions of Assurance 7(b):

1. The (grantee, licensee, permittee, etc., as appropriate) for himself/herself, his/her heirs, personal representatives, successors in interest, and assigns, as a part of the consideration hereof, does hereby covenant and agree (in the case of deeds and leases add, "as a covenant running with the land") that (1) no person on the ground of race, color, or national origin, will be excluded from participation in, denied the benefits of, or be otherwise subjected to discrimination in the use of said facilities, (2) that in the construction of any improvements on, over, or under such land, and the furnishing of services thereon, no person on the ground of race, color, or national origin, will be excluded from participation in, denied the benefits of, or otherwise be subjected to discrimination, (3) that the (grantee, licensee, lessee, permittee, etc.) will use the premises in compliance with all other requirements imposed by or pursuant to the Acts and Regulations, as amended, set forth in this Assurance.
2. With respect to (licenses, leases, permits, etc.), in the event of breach of any of the above Non-discrimination covenants, the NCDOT will have the right to terminate the (license, permit, etc., as appropriate) and to enter or re-enter and repossess said land and the facilities thereon, and hold the same as if said (license, permit, etc., as appropriate) had never been made or issued. \*
3. With respect to deeds, in the event of breach of any of the above Nondiscrimination covenants, the NCDOT will there upon revert to and vest in and become the absolute property of the NCDOT and its assigns. \*

(\*Reverter clause and related language to be used only when it is determined that such a clause is necessary to make clear the purpose of Title VI.)

## APPENDIX

### **WORK ZONE TRAFFIC CONTROL GUIDANCE FOR LITTER/DEBRIS REMOVAL**

**The Contractor performing Work Zone Traffic Control shall have a minimum of one (1) NCDOT Certified Work Zone Supervisor.**

#### GENERAL

- Workers that are involved in litter/debris removal operations shall comply with the following:
  - Wear NCDOT approved safety vests for day time operations
- Litter/debris removal operations shall be confined within a maximum 5 mile stretch of roadway in a work period
- Conduct litter/debris removal operations behind lane closures at any location where workers and/or equipment are encroaching into the travel lanes. Lane closures shall be installed according to Roadway Standard Drawings 1101.02. Encroaching into travel lanes includes exiting and entering vehicles that are parked on shoulders.
- For operations where workers and equipment are confined to the shoulders, comply with the following:

#### On Multilane Divided Facilities

- A Truck Mounted Attenuator (TMA) shall be used to protect each group of workers removing litter/debris if the shoulder is wide enough to fit a TMA.
- If a TMA is not used, a shoulder closure shall be installed
- A shoulder closure shall be installed in locations where the shoulder is too narrow to accommodate a TMA without encroaching into the traffic lane
- A shoulder closure or a TMA shall be used on the median side of the opposite direction if the following condition exists:
  - Where workers and/or equipment are within 15' from the adjacent travel lane in the opposite direction and are not protected from traffic in the opposite direction by any type of positive median protection such as concrete barrier, guardrail, or guiderail.
- Shoulder closures shall be installed according to Roadway Standard Drawing 1101.04

#### Two-Lane, Two-Way Facilities over 4000 ADT

- A shoulder closure shall be installed if workers are to be present more than one hour at any location.
- If workers are to be present less than one hour, use portable advance warning signs (one in each direction) reading "LITTER PICKUP AHEAD".
- Shoulder closures shall be installed according to Roadway Standard Drawing 1101.04

#### Two-Lane, Two-Way Facilities 4000 ADT or lower

- Use portable advance warning signs (one in each direction) reading "LITTER PICKUP AHEAD". The sign should be located 500 feet ahead of the area where workers and or equipment will be present during the operation.

**PLEASE NOTE THE FOLLOWING EXCEPTIONS:**

The moving caravan operation will NOT be required to be used while retrieving bagged litter/debris in areas where the Contractor's equipment is able to traverse the shoulder without encroaching into the travel lanes.

The truck mounted attenuator (TMA) will NOT be required to be used while retrieving bagged litter/debris in areas where the Contractor's equipment is able to traverse the shoulder without encroaching into the travel lanes.

If the vehicle the Contractor is using is wider than the width of the shoulder a moving caravan operation WILL be required if the Contractor elects to allow the vehicle to encroach into the travel.

The Contractor may elect to park the vehicle outside of these narrow areas and remove bags by hand in lieu of the moving caravan operation.

The truck mounted attenuator (TMA) will NOT be required to protect workers picking up litter/debris if the Contractor's operations are carried out in such a way that the workers are positioned individually along a roadway and not travelling in a concentrated group.

If a concentrated group of workers are gathered together in a formation to conduct clean up then they shall be protected by a TMA.

The shoulder closure will NOT be required unless equipment remains stationary for more than 5 minutes and/or a concentrated group of workers are within 15 feet of an open travel lane and the area is not protected by barrier or guardrail.

The lane closure will NOT be required unless equipment remains stationary for more than five minutes and/or a concentrated group of workers are within 10 feet of an open travel lane and the area is not protected by barrier or guardrail."

A concentrated group of workers is defined as three (3) or more workers within a 500' section and within fifteen (15) feet from a travel lane, measured along the edge of the roadway, of other workers.

**WORK ZONE SIGNING:**

All portable signs and stands must meet or exceed the requirements of the National Cooperative Highway Research Program Report 350 for Work Zone Category II Devices, and be listed on North Carolina's approved products list or accepted as traffic qualified by the Traffic Control Section. Use portable work zone signs and stands specifically designed for one another.

Refer to the following:

- SSRS 1089 for material specification
- SSRS 1110 for construction specification
- RSD 1110 for clearance specification

The W10-10A shall be used for high volume primary and secondary routes. Its dimensions are 48" X 48". It shall be mounted at a minimum height of five (5) feet above the elevation of the outermost edge of travel. The sign shall read "LITTER PICKUP AHEAD", and should be relocated accordingly during the prosecution of work. Additional signs may be required by the Engineer at interchanges.

Sign Detail for Litter/Debris Removal Vehicle

**DETAIL OF SIGN TO BE MOUNTED  
ON BACK OF ALL VEHICLES USED FOR  
LITTER/DEBRIS REMOVAL**

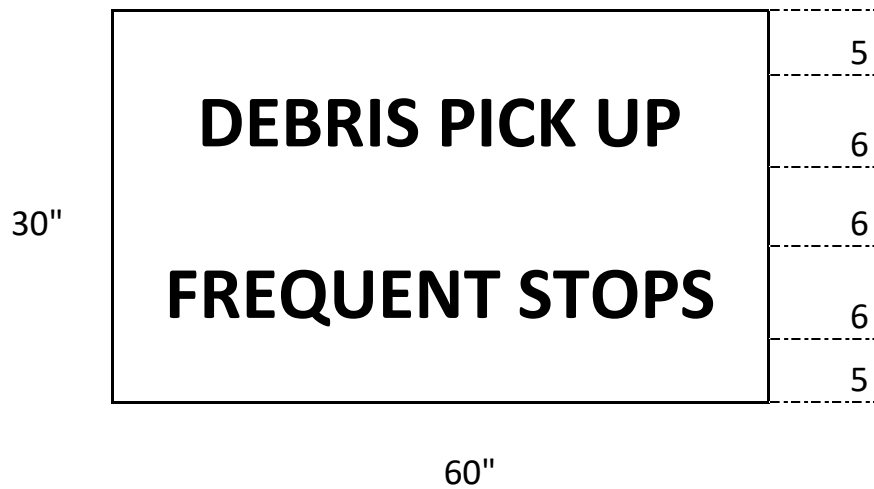

Lettering -  
Black

Background - Fluorescent Orange (Retroreflective)

**Service Vehicles**

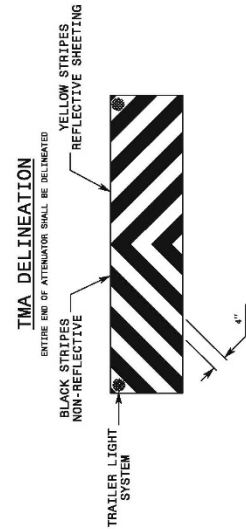
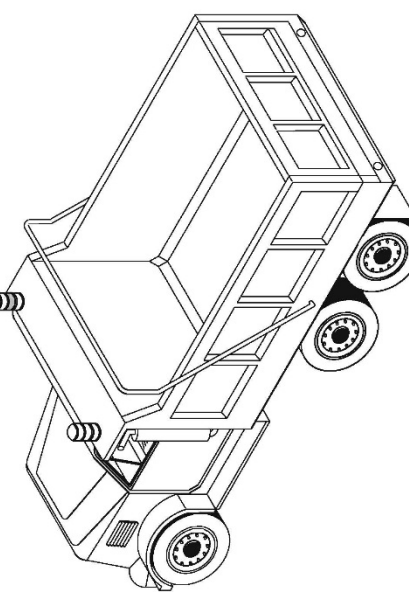
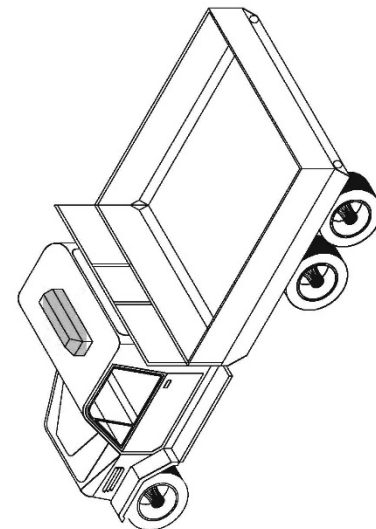
STATE OF NORTH CAROLINA DEPT. OF TRANSPORTATION DIVISION OF HIGHWAYS RALEIGH, N.C.	1-12	ENGLISH STANDARD DRAWING FOR <b>WORK VEHICLE LIGHTING SYSTEMS                  AND TMA DELINEATION</b>	SHEET 1 OF 1 <b>1165.01</b>	
<p><b>LIGHT SYSTEM OPTIONS</b></p> <p>I. TRUCKS WITH TMA DUMP BODIES. RANGE OF EITHER:</p> <p>A. LIGHT BARS (DO NOT INCLUDE LETTER LED OR ROTATING FLASH WITH RED/AMBER LIGHTS AND WHITE LIGHT BARS) OR LIGHT BARS WITH RED/AMBER LIGHTS AND WHITE LIGHT BARS (ALL WHITE LIGHT SYSTEMS ARE PROHIBITED).</p> <p>B. 2 HIGH INTENSITY STRIPES (CLASS 2) - AMBER LED/AMBER FLASH AND RED/AMBER LED/AMBER FLASH OR RED/AMBER LED/AMBER FLASH AND WHITE LED/AMBER FLASH (NOT REQUIRED, BUT ENCOURAGED).</p> <p>II. TRUCKS WITH DUMP BODIES - (NOT REQUIRED, BUT ENCOURAGED)</p> <p>A. AMBER LED/AMBER FLASH AND WHITE LED/AMBER FLASH (NOT REQUIRED, BUT ENCOURAGED).</p> <p>B. AMBER LED/AMBER FLASH AND WHITE LED/AMBER FLASH (NOT REQUIRED, BUT ENCOURAGED).</p>		<p><b>TMA DELINEATION</b></p> <p>ENTIRE END OF ATTENUATOR SHALL BE DELINEATED</p>  <p>BLACK STRIPES NON-REFLECTIVE</p> <p>YELLOW STRIPES REFLECTIVE SHEETING</p> <p>TRAILER LIGHT SYSTEM</p> <p>4" TYP.</p>	<p><b>DUMP BODY</b></p> 	<p><b>NON-DUMP BODY</b></p> 
<p><b>GENERAL NOTES FOR TMA REQUIREMENTS</b></p> <p>1- WHEN TMA'S USED FOR SHADOW VEHICLES, CONTACT THE TMA MANUFACTURER FOR SPECIFIC TRUCK REQUIREMENTS.</p> <p>2- TMA MUST MEET OR EXCEED THE REQUIREMENTS OF MICHIGAN 350 TEST LEVEL II FOR WORK ZONES WITH RED/AMBER LIGHTS AND WHITE LIGHT BARS. TMA MUST MEET OR EXCEED THE REQUIREMENTS OF MICHIGAN 350 TEST LEVEL II FOR WORK ZONES WITH RED/AMBER LIGHTS AND WHITE LIGHT BARS. TMA MAY EITHER BE TRUCK MOUNTED OR TRAILER MOUNTED.</p> <p>3- SEE THE DEPARTMENT'S APPROVED PRODUCT LIST AT <a href="https://apps.dot.state.nc.us/vendor/approvedproducts">https://apps.dot.state.nc.us/vendor/approvedproducts</a>.</p>		ENGLISH STANDARD DRAWING FOR <b>WORK VEHICLE LIGHTING SYSTEMS                  AND TMA DELINEATION</b>	SHEET 1 OF 1 <b>1165.01</b>	



**Typical Sections for Litter Pickup Operation**

**TYPICAL INTERCHANGE CONFIGURATIONS**

**SHOWING THE LIMITS FOR**

**LITTER/DEBRIS REMOVAL.**

- Litter removal includes all areas visible from the road



Litter Pickup Operation Diagrams

Diagram 1

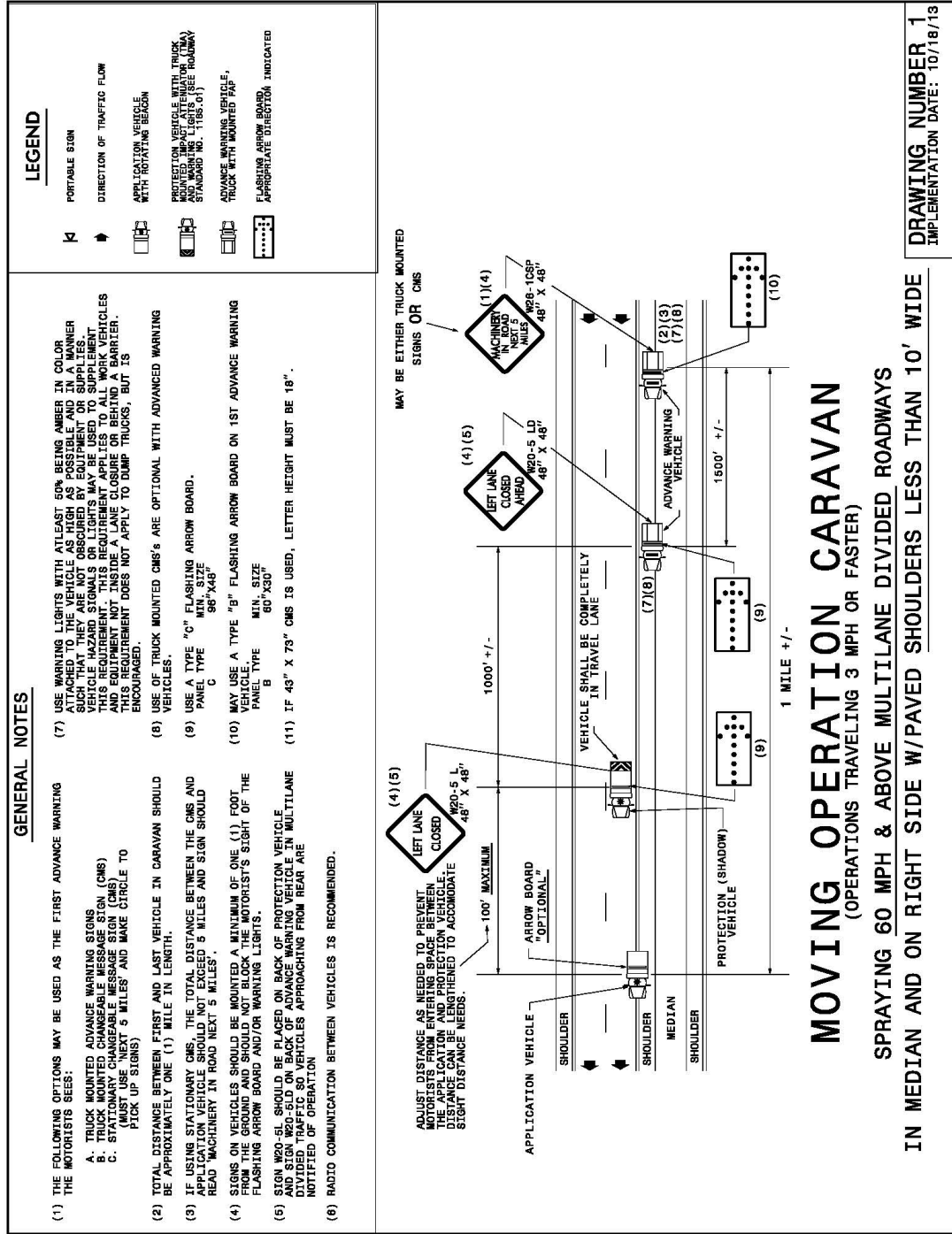

**Diagram 2**

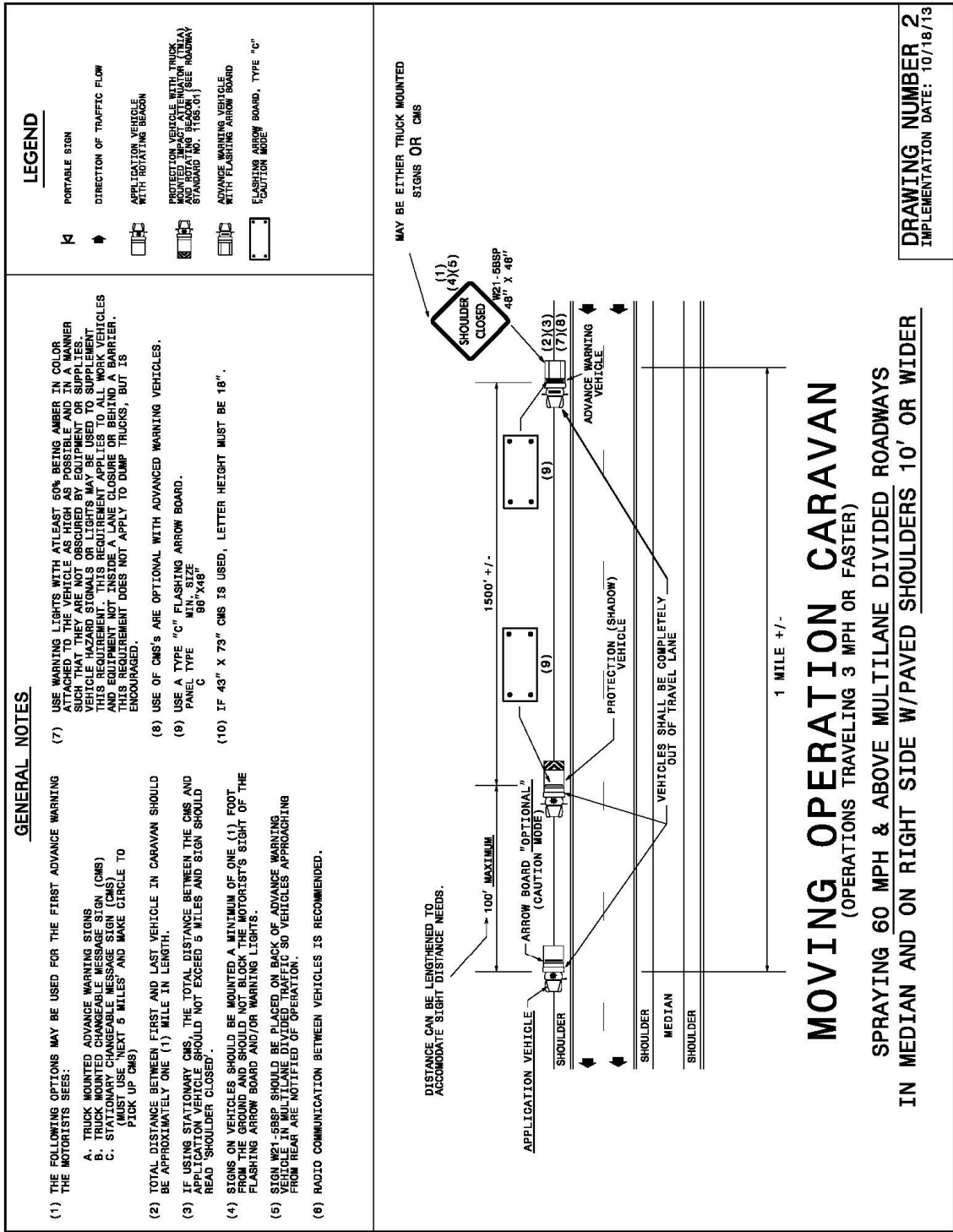

**Diagram 3**

**GENERAL NOTES**

(1) THE FOLLOWING OPTIONS MAY BE USED AS THE FIRST ADVANCE WARNING THE MOTORISTS SEES:  
 A. TRUCK MOUNTED ADVANCE WARNING SIGNS  
 B. MOVING CHANGEABLE MESSAGE SIGN (CMS)

(2) TOTAL DISTANCE BETWEEN FIRST AND LAST VEHICLE IN CARAVAN SHOULD BE APPROXIMATELY ONE (1) MILE IN LENGTH.

(3) SIGNS ON VEHICLES SHOULD BE MOUNTED A MINIMUM OF ONE (1) FOOT FROM THE GROUND AND SHOULD NOT BLOCK THE MOTORIST'S SIGHT OF THE FLASHING ARROW BOARD AND/OR WARNING LIGHTS.

(4) SIGN W20-5L SHOULD BE PLACED ON BACK OF PROTECTION VEHICLE AND DIVERTED TRAFFIC TO OTHER MULTILANE DIVIDED ROADWAYS. MULTILANE NOTIFIED OF OPERATION.

(5) RADIO COMMUNICATION BETWEEN VEHICLES IS RECOMMENDED.

(6) USE WARNING LIGHTS WITH ATLEAST 50% BEING AMBER IN COLOR ATTACHED TO THE VEHICLE AS HIGH AS POSSIBLE AND IN A MANNER SUCH THAT THEY ARE NOT OBSCURED BY EQUIPMENT OR SUPPLIES. VEHICLE HAZARD SIGNALS OR LIGHTS MAY BE USED TO SUPPLEMENT THIS REQUIREMENT. THIS REQUIREMENT DOES NOT APPLY TO DUMP TRUCKS, BUT IS ENCOURAGED.

(7) USE OF CMS'S ARE OPTIONAL WITH ADVANCED WARNING VEHICLES.

(8) USE A TYPE "C" FLASHING ARROW BOARD.  
 PANEL TYPE C  
 MIN. SIZE 96"X48"

(9) USE A TYPE "B" FLASHING ARROW BOARD.  
 PANEL TYPE B  
 MIN. SIZE 60"X30"

(10) IF 49" X 73" CMS IS USED, LETTER HEIGHT MUST BE 18".

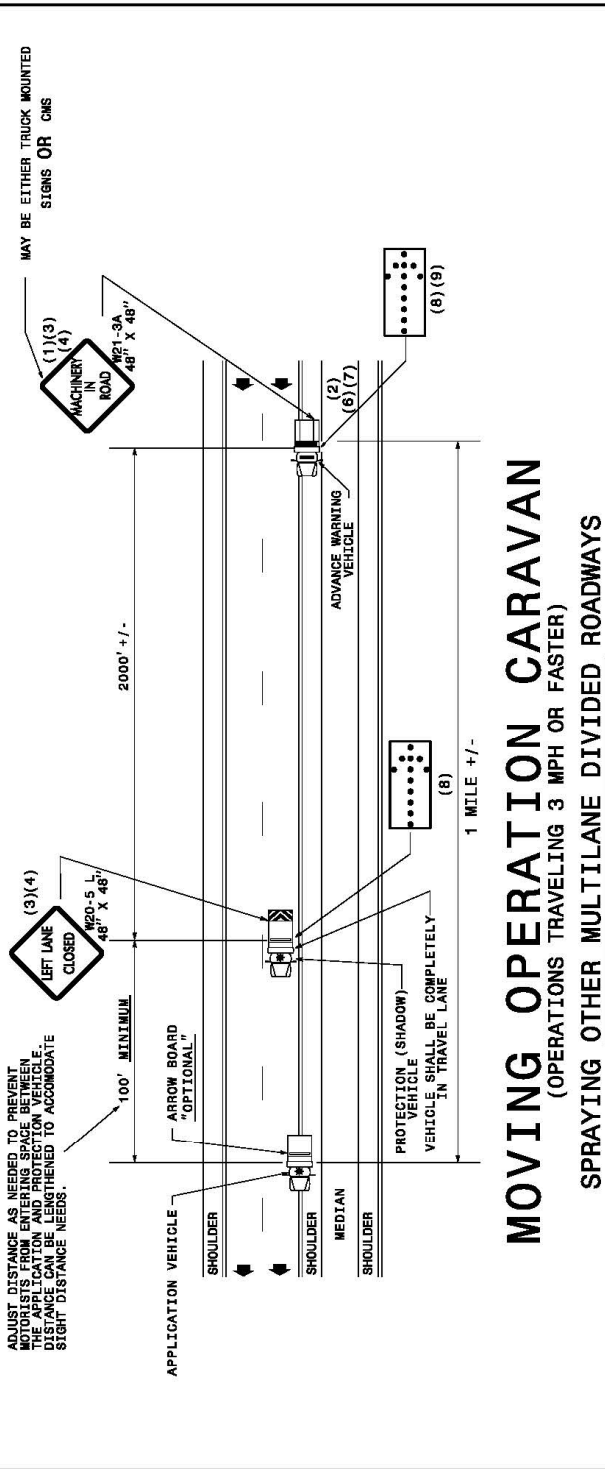
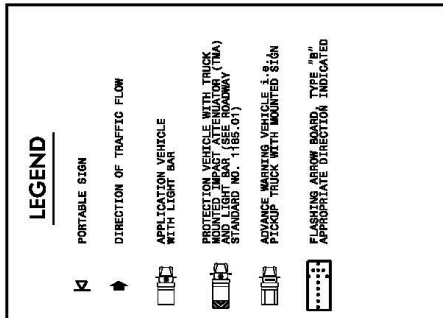

**MOVING OPERATION CARAVAN**  
 (OPERATIONS TRAVELING 3 MPH OR FASTER)  
 SPRAYING OTHER MULTILANE DIVIDED ROADWAYS  
 IN MEDIAN AND ON RIGHT SIDE W/PAVED SHOULDERS LESS THAN 10' WIDE

**DRAWING NUMBER 3**  
 IMPLEMENTATION DATE: 10/18/13

**Diagram 4**

**GENERAL NOTES**

(1) THE FOLLOWING OPTIONS MAY BE USED AS THE FIRST ADVANCE WARNING THE MOTORISTS SEE:

A. TRUCK MOUNTED ADVANCE WARNING SIGNS  
 B. MOVING CHANGEABLE MESSAGE SIGN (CMS)  
 C. GROUND MOUNTED ADVANCE WARNING SIGNS (MUST USE "NEXT 5 MILES" AND MAKE CIRCLE TO INDICATE DISTANCE TO PROTECTION VEHICLE)  
 D. STATIONARY CHANGEABLE MESSAGE SIGN (CMS) (MUST USE "NEXT 5 MILES" AND MAKE CIRCLE TO PICK UP CMS)

(2) TOTAL DISTANCE BETWEEN FIRST AND LAST VEHICLE IN CARAVAN SHOULD BE APPROXIMATELY ONE (1) MILE IN LENGTH.

(3) IF USING GROUND MOUNTED ADVANCE WARNING SIGNS OR STATIONARY OR CMS, THE TOTAL DISTANCE BETWEEN THE FIRST ADVANCE WARNING SIGN AND APPLICATION VEHICLE SHOULD NOT EXCEED 5 MILES, AND SIGN W26-1CSP SHOULD READ "MACHINERY IN ROAD NEXT 5 MILES".

(4) SIGNS ON VEHICLES SHOULD BE MOUNTED A MINIMUM OF ONE (1) FOOT FROM THE GROUND AND SHOULD NOT BLOCK THE MOTORIST'S SIGHT OF THE FLASHING ARROW BOARD AND/OR LIGHT BAR.

(5) SIGN W26-1BSP OR R4-7A SHOULD BE PLACED ON FRONT OF THE APPLICATION VEHICLE AND SIGN W26-1BSP OR W21-3A ON BACK OF THE PROTECTION VEHICLE IN TWO-LANE, TWO-WAY TRAFFIC SO VEHICLE APPROACHING FROM THE FRONT AND REAR ARE NOTIFIED OF OPERATION.

(6) IF A LEAD VEHICLE IS ADDED TO OPERATION, IT SHOULD HAVE THE SAME ADVANCE WARNING SIGNS AS THE APPLICATION VEHICLE SHOWN BELOW.

(7) RADIO COMMUNICATION BETWEEN VEHICLES IS RECOMMENDED.

(8) USE WARNING LIGHTS WITH AT LEAST 50% BEING AMBER IN COLOR ATTACHED TO THE VEHICLE AS HIGH AS POSSIBLE AND IN A MANNER SUCH THAT THEY ARE NOT OBSCURED BY EQUIPMENT OR SUPPLIES. VEHICLE HAZARD SIGNALS OR LIGHTS MAY BE USED TO SUPPLEMENT THIS REQUIREMENT. THIS REQUIREMENT APPLIES TO ALL WORK VEHICLES OPERATING AS PART OF A CONSTRUCTION PROJECT. THIS REQUIREMENT DOES NOT APPLY TO DUMP TRUCKS, BUT IS ENCOURAGED.

(9) USE OF CMS'S ARE OPTIONAL WITH ADVANCED WARNING VEHICLES.

(10) USE A TYPE "B" FLASHING ARROW BOARD.  
 PANEL TYPE MIN. SIZE  
 B 60" X 30"

(11) IF 43" X 73" CMS IS USED, LETTER HEIGHT MUST BE 18".

**LEGEND**

PORTABLE SIGN

DIRECTION OF TRAFFIC FLOW

APPLICATION VEHICLE WITH ROTATING BEAM

PROTECTION VEHICLE WITH TRUCK MOUNTED IMPACT ATTENUATOR (TMA) AND MOUNTING BEAM (SEE ROADWAY STANDARDS NO. 196-30)

ADVANCE WARNING VEHICLE 1.6 SIGN PICKUP TRUCK WITH MOUNTED SIGN

FLASHING ARROW BOARD, TYPE "B"

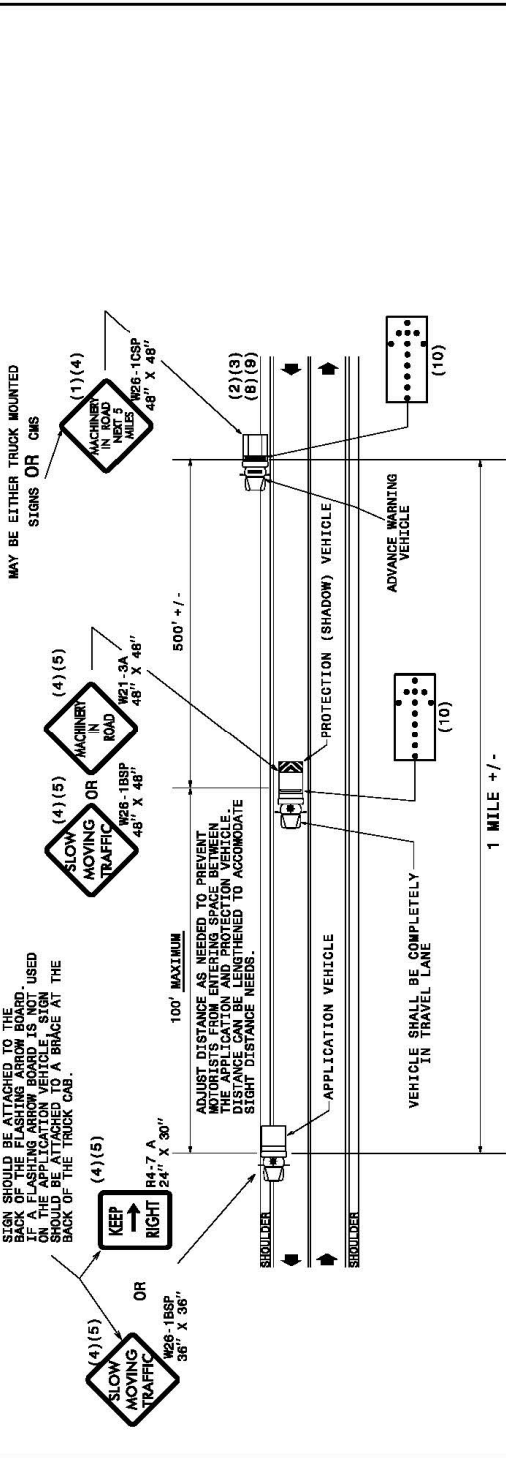

**MOVING OPERATION CARAVAN**  
 (OPERATIONS TRAVELING 3 MPH OR FASTER)  
 SPRAYING TWO-LANE TWO-WAY ROADWAYS  
 WITH ADT GREATER THAN 5000

**DRAWING NUMBER 4**  
 IMPLEMENTATION DATE: 10/18/13

**Diagram 5**

**GENERAL NOTES**

(1) THE FOLLOWING OPTIONS MAY BE USED AS THE FIRST ADVANCE WARNING THE MOTORISTS SEE:

- A. TRUCK MOUNTED ADVANCE WARNING SIGNS
- B. MOVING CHANGEBLE MESSAGE STON (CMS)
- C. GROUND MOUNTED ADVANCE WARNING SIGNS (W28-1CSP) (MUST USE "NEXT 5 MILES" AND MAKE CIRCLE TO PICK UP SIGNS)
- D. GROUND MOUNTED MESSAGE STON (CMS) (MUST USE "NEXT 5 MILES" AND MAKE CIRCLE TO PICK UP CMS)

(2) TOTAL DISTANCE BETWEEN FIRST AND LAST VEHICLE IN CARAVAN SHOULD BE APPROXIMATELY ONE (1) MILE IN LENGTH.

(3) IF USING GROUND MOUNTED ADVANCE WARNING SIGNS OR STATIONARY CMS, THE TOTAL DISTANCE BETWEEN THE FIRST ADVANCE WARNING SIGN OR CMS AND APPLICATION VEHICLE SHOULD NOT EXCEED 5 MILES AND SIGN W21-3BSP SHOULD READ "MACHINERY IN ROAD NEXT 5 MILES".

(4) SIGNS ON VEHICLES SHOULD BE MOUNTED A MINIMUM OF ONE (1) FOOT FROM THE GROUND AND SHOULD NOT BLOCK THE MOTORIST'S SIGHT OF THE FLASHING ARROW BOARD AND/OR WARNING LIGHTS.

(5) SIGN W26-1BSP OR R4-7A SHOULD BE PLACED ON FRONT OF THE APPLICATION VEHICLE AND SIGN W26-1BSP OR W21-3A ON BACK OF THE PROTECTION VEHICLE IN TWO-LANE, TWO-WAY TRAFFIC SO VEHICLE APPROACHING FROM THE FRONT AND REAR ARE NOTIFIED OF OPERATION.

**LEGEND**

	PORTABLE SIGN
	DIRECTION OF TRAFFIC FLOW
	APPLICATION VEHICLE WITH ROTATING BEACON
	ADVANCE WARNING VEHICLE
	PICKUP TRUCK WITH MOUNTED SIGN
	FLASHING ARROW BOARD, TYPE "B"

**MOVING OPERATION CARAVAN**  
 (OPERATIONS TRAVELING 3 MPH OR FASTER)  
 SPRAYING TWO-LANE TWO-WAY ROADWAYS  
 WITH ADT LESS THAN OR EQUAL TO 5000

**DRAWING NUMBER 5**  
 IMPLEMENTATION DATE: 10/18/13

- GENERAL NOTES**
- (6) IF A LEAD VEHICLE IS ADDED TO OPERATION, IT SHOULD HAVE THE SAME ADVANCE WARNING SIGNS AS THE APPLICATION VEHICLE SHOWN BELOW.
- (7) RADIO COMMUNICATION BETWEEN VEHICLES IS RECOMMENDED.
- (8) USE WARNING LIGHTS WITH ATLEAST 50% BEING AMBER IN COLOR ATTACHED TO THE VEHICLE AS HIGH AS POSSIBLE AND IN A MANNER SUCH THAT THEY ARE NOT OBSCURED BY EQUIPMENT OR SUPPLIES. FLASHING LIGHTS SHOULD BE USED TO ADVISE TRUCKS OF THE PRESENT THIS REQUIREMENT DOES NOT APPLY TO ALL WORK VEHICLES AND EQUIPMENT NOT INSIDE A LANE CLOSURE OR BEHIND A BARRIER. THIS REQUIREMENT DOES NOT APPLY TO DUMP TRUCKS, BUT IS ENCOURAGED.
- (9) USE OF CMS'S ARE OPTIONAL WITH ADVANCED WARNING VEHICLES.
- (10) USE A TYPE "B" FLASHING ARROW BOARD.  
 PANEL TYPE MIN. SIZE 80"X30"  
 B
- (11) IF 43" X 73" CMS IS USED, LETTER HEIGHT MUST BE 18".

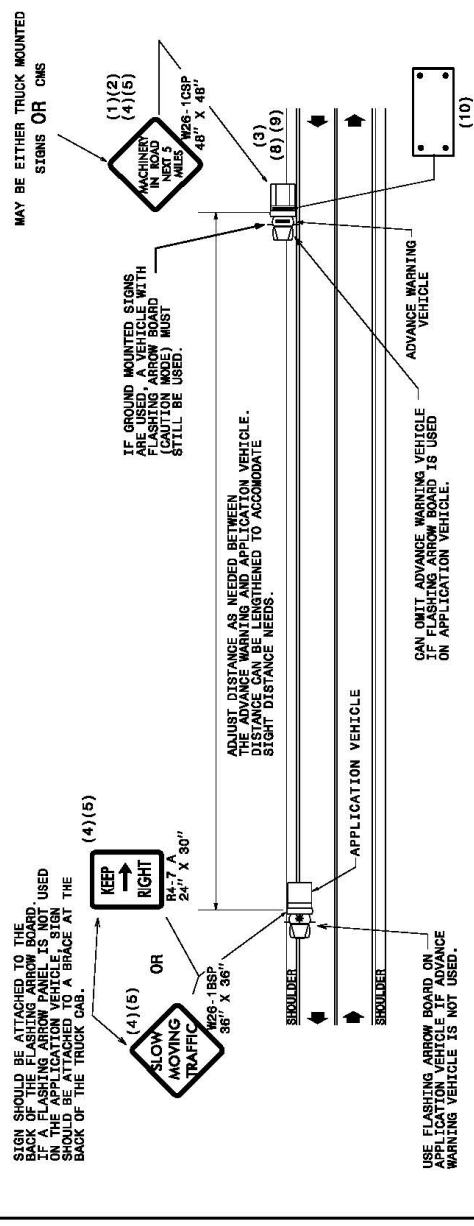

**DRAWING NUMBER 5**  
 IMPLEMENTATION DATE: 10/18/13

**Multi-lane Operation Diagrams**

**Diagram 1**

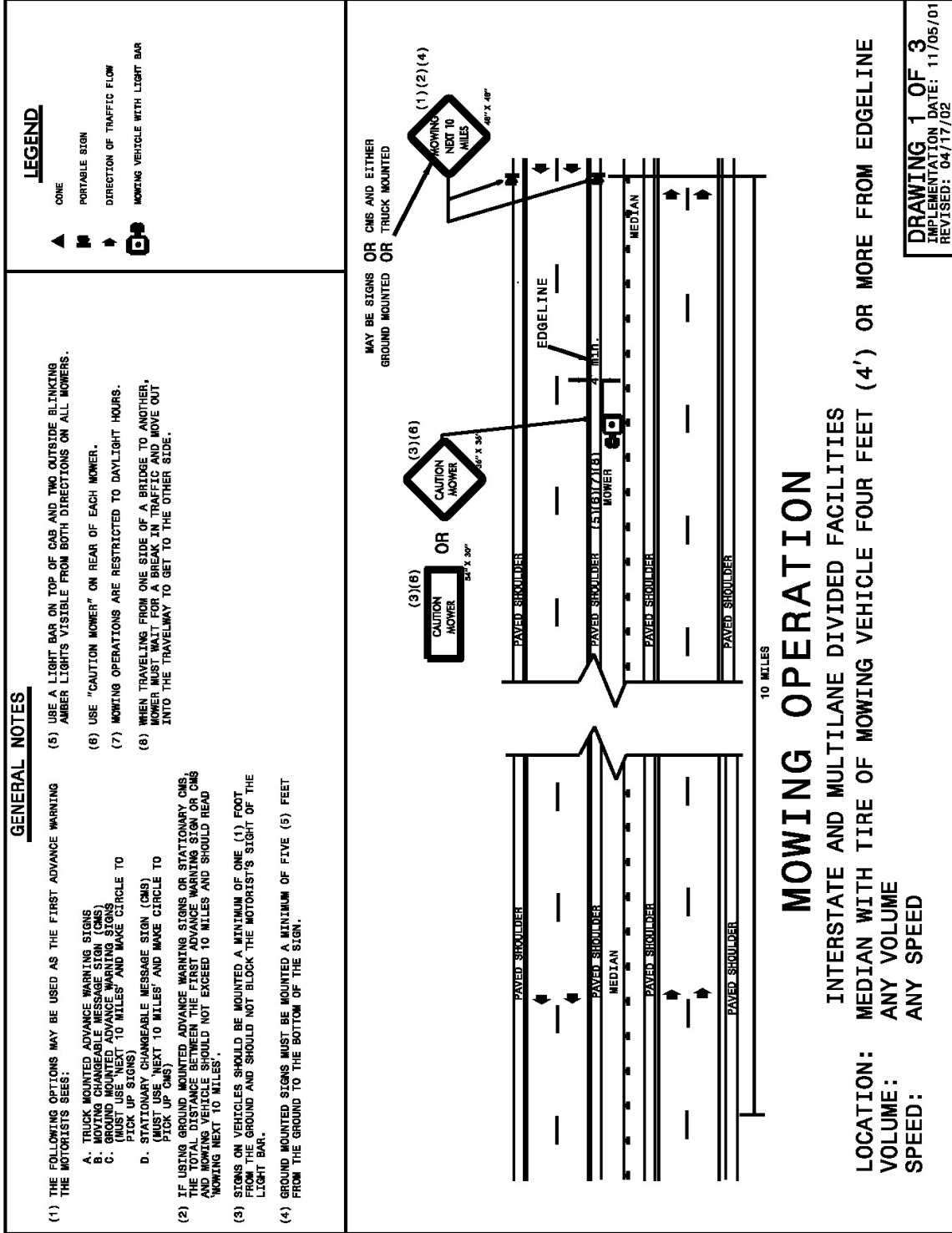

**DRAWING 1 OF 3**  
 IMPLEMENTATION DATE: 11/05/01  
 REVISED: 04/17/02



**Diagram 2**

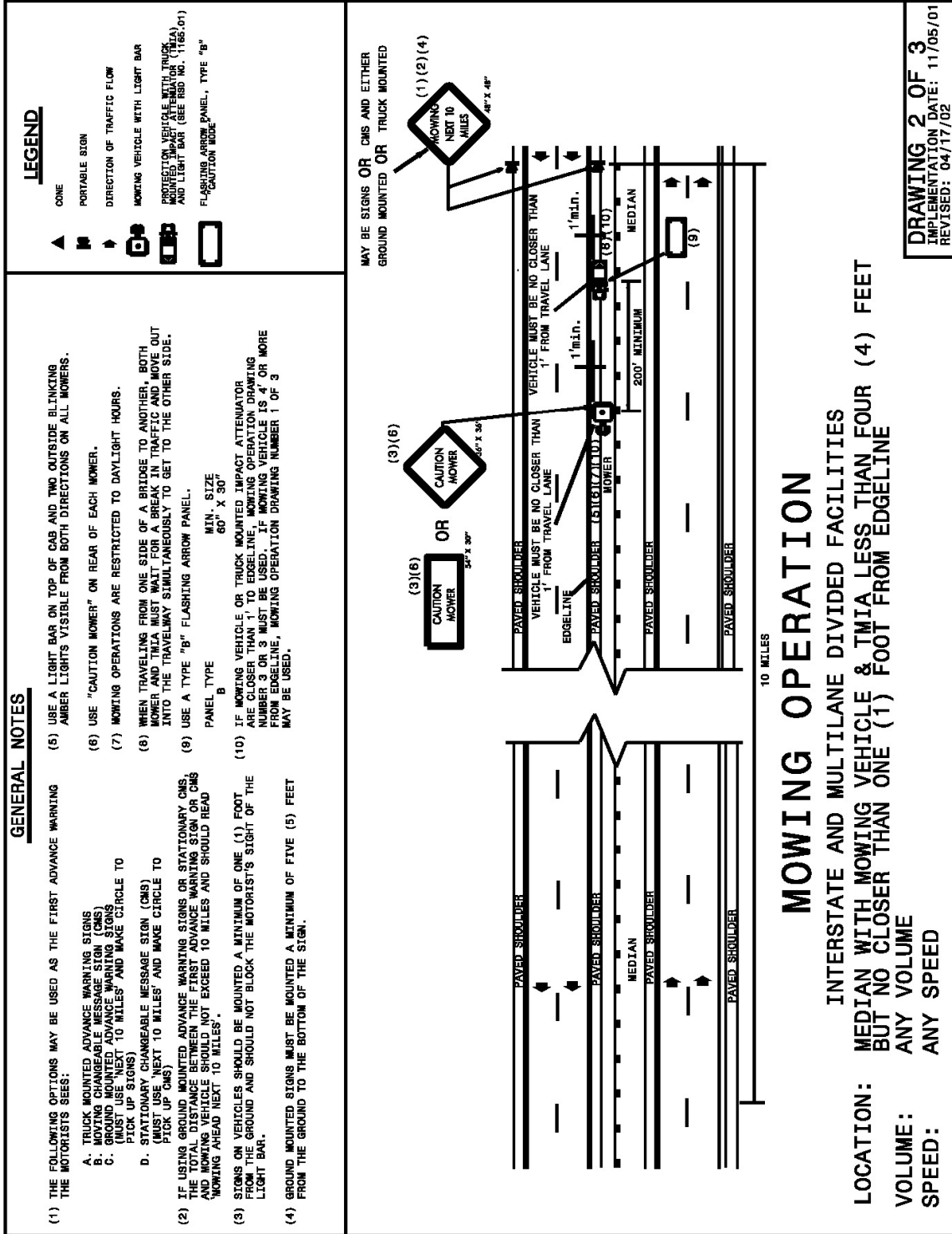

**DRAWING 2 OF 3**  
 IMPLEMENTATION DATE: 11/05/01  
 REVISED: 04/17/02



Diagram 3

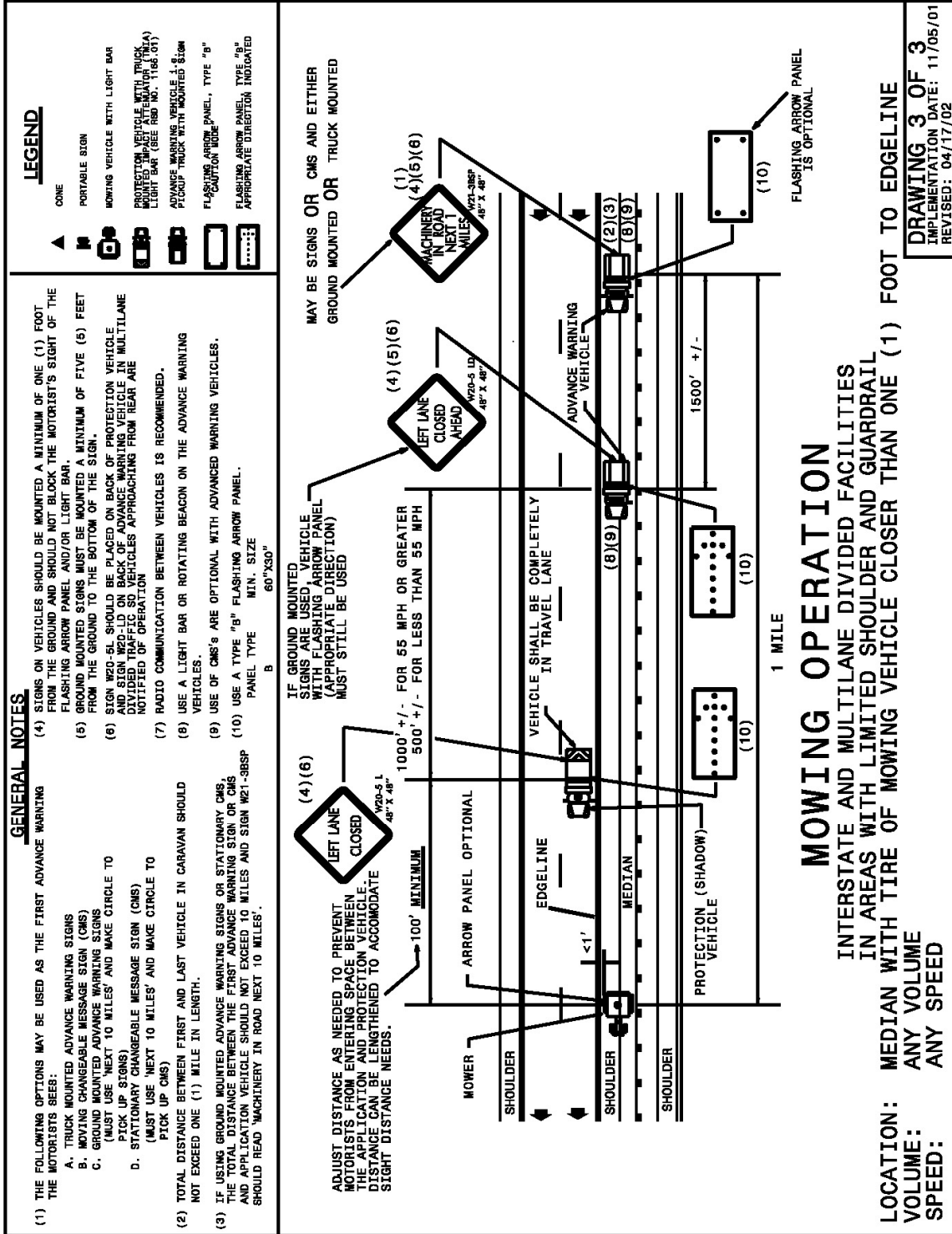

**BREAKDOWN OF ROUTES AND MILEAGE**

<b>Contract Litter Removal for Richmond County</b>					
<b>Primary Highways</b>					
<b>Route</b>	<b>Remarks</b>	<b>Road Length</b>		<b>Cleanup Cycles per Year</b>	<b>Corridor Miles of Cleanup per Year</b>
		<b>Primary Undivided</b>	<b>Interstate &amp; Primary Divided</b>		
I-73 / I-74	From Richmond-Montgomery C/Lto End Interstate.		13.34	12	160.08
US 1	From US 1 / US 220 interchange South of US 74 BUS		0.62	6	3.72
US 1	Not Mown - From Beg. Div. Hwy @ E. Franklin St. (SR1561) to End Div. Hwy E. Washington St		0.30	6	1.8
US 1	From Begin Div. Hwy @ Old Aberdeen Rd (SR1426) to End Div. Hwy @ Wiregrass Rd (SR1640)		2.00	6	12
US 1	From Begin Div. Hwy @ Little Rd (SR1004) to Moore County Line.		3.54	6	21.24
US 74	From Richmond/Anson Co line to Richmond/Scotland Co line		17.80	6	106.8
US 74 BUS	From US 74 / US 74 BUS interchange to end Div. Hwy @ Mcnair St (SR1184)		4.68	6	28.08
US 74 BUS	From Begin Div. Hwy East of Biltmore Dr (SR1925) to End Div. Hwy East of Circlewood Dr (SR1639)		2.70	6	16.2
US 74 BUS	From Begin grass median East of NC 381 to US 74 / US 74 BUS interchange.		1.72	6	10.32
US 220	From the intersection of US 1 / US 220 to end grass median @ Midway Rd (SR1124) overpass.		0.46	6	2.76
US 220	From begin grass median north of N Lee St (SR1405) to begin Interstate I-73.		3.85	6	23.1
US 1	From SC line to US 1 US 220 interchange	10.57		6	63.42
US 1	From US 1 / US 220 interchange to US 74 BUS	0.52		6	3.12
US 1	Not Mown - From US 74 BUS to Beg. Div. Hwy @ E. Frankling St. (SR1561)	0.13		6	0.78
US 1	Not Mown - From End Div. Hwy @ E. Washington St. to Beg. Div. Hwy. @ Old Aberdeen Rd (SR1426)	1.99		6	11.94
US 1	From End Div. Hwy @ Wiregrass Rd (SR1640) to Begin Div. Hwy @ Little Rd (SR1004)	7.92		6	47.52
US 220	From end grass median @ Midway Rd (SR1124) overpass to begin grass median north of N Lee St (SR1405)	0.94		6	5.64
US 220	From US 220 / I-73 interchange to Richmond-Montgomery Co. Line	10.41		6	62.46
US 74 BUS	From end Div. Hwy @ Mcnair St (SR1184) to US 220.	1.01		6	6.06
US 74 BUS	Not Mown - From US 220 to Begin Div. Hwy East of Biltmore Dr (SR1925)	2.48		6	14.88
US 74 BUS	Not Mown - From End Div. Hwy East of Circlewood Dr (SR1639) to Fifth St (SR1616)	1.66		6	9.96
US 74 BUS	From Fifth St (SR1616) to Beg grass median east of NC 381.	1.09		6	6.54
NC 38	From US 74 BUS to SC line.	5.51		6	33.06
NC 73	From Richmond-Montgomery Co line (West Side) to US 220.	12.07		6	72.42
NC 73	From US 220 to Richmond-Montgomery Co line (East Side)	3.63		6	21.78
NC 109	From Richmond-Anson Co line to Richmond-Montgomery Co line.	4.29		6	25.74
NC 177	From SC line to Battley Dairy Rd (SR1900)	6.60		6	39.6
NC 177	Not Mown - From Battley Dairy Rd (SR1900) to Earl Franklin Rd (SR1627)	1.32		6	7.92
NC 177	From Earl Franklin Rd (SR1627) to US 1	8.40		6	50.4
NC 381	From US 74 BUS to Richmond-Scotland Co line.	4.51		6	27.06
<b>Sub-Totals</b>		<b>85.05</b>	<b>37.67</b>		<b>736.32</b>
<b>Cycles</b>		<b>6</b>	<b>6</b>		
<b>Totals</b>		<b>510.30</b>	<b>226.02</b>		<b>736.32</b>
<b>Totals</b>			<b>13.34</b>		<b>160.08</b>
<b>Secondary Highways</b>					
<b>Richmond County</b>		<b>Secondary Undivided</b>		<b>Cleanup Cycles per Year</b>	<b>Corridor Miles of Cleanup per Year</b>
<b>Misc Secondary Undivided Highways as requested</b>		<b>35.00</b>		<b>6</b>	<b>210</b>

<b>Contract Litter Removal for Montgomery County</b>					
<b>Primary Highways</b>					
<b>Route</b>	<b>Remarks</b>	<b>Road Length</b>		<b>Cleanup Cycles per Year</b>	<b>Corridor Miles of Cleanup per Year</b>
		<b>Primary Undivided</b>	<b>Road Length Interstate &amp; Primary Divided</b>		
I-73&74	Randolph C/L to Richmond C/L		24.48	12	293.76
NC Hwy 24/27			8.37	6	50.22
NC Bus 24/27		2.42		6	14.52
NC Hwy 24/27		12.89		6	77.34
NC Hwy 73		13.27		6	79.62
NC Hwy 109		25.34		6	152.04
NC Hwy 134		10.17		6	61.02
NC Hwy 211		1.62		6	9.72
NC Hwy 731		19.13		6	114.78
US 220 Alt (Bus)		22.41		6	134.46
Troy City Limits NC 134, 109, 24/27	From Troy City Limit Sign to town.	3.66		6	21.96
Candor City Limits US 220 Alt, NC 211	From Candor City Limit Sign to town.	1.3		6	7.8
Biscoe City Limits US 220 Alt, NC 24/27	From Biscoe City Limit Sign to town.	2.44		6	14.64
Star City Limits US 220 Alt	From Star City Limit Sign to town.	0.8		6	4.8
Mt. Gilead City Limits NC 731, 73, 109	From Mt. Gilead City Limit Sign to town.	3.47		6	20.82
<b>Sub-Totals</b>		<b>118.92</b>	<b>8.37</b>		<b>763.74</b>
<b>Cycles</b>		<b>6</b>	<b>6</b>		
<b>Totals</b>		<b>713.52</b>	<b>50.22</b>		<b>763.74</b>
<b>Totals</b>		<b>Interstate</b>	<b>24.48</b>		<b>293.76</b>
<b>Secondary Highways</b>					
<b>Montgomery County</b>			<b>Secondary Undivided</b>	<b>Cleanup Cycles per Year</b>	<b>Corridor Miles of Cleanup per Year</b>
<b>Misc Secondary Undivided Highways as requested</b>			<b>30.00</b>	<b>6</b>	<b>180</b>

<b>Contract Litter Removal for Randolph County</b>				
<b>Secondary Highways</b>				
<b>Randolph County</b>		<b>Secondary Undivided</b>	<b>Cleanup Cycles per Year</b>	<b>Corridor Miles of Cleanup per Year</b>
<b>Misc Secondary Undivided Highways as requested</b>		<b>80.00</b>	<b>6</b>	<b>480</b>

## **PREPARATION AND SUBMISSION OF TRADITIONAL PAPER BIDS**

As stated under “AWARD OF CONTRACT” above, the Engineer will evaluate the Bidder's proposal to determine the responsibility of the bid and insure compliance with contract. The Engineer, using his/her discretion, will determine whether a bidder is “responsible” and capable of performing the required work. The Bidder should demonstrate an understanding of the requirements of the contract, and that the requirements have been addressed in his/her bid to the satisfaction of the Engineer. The Bidder should demonstrate that he/she is capable of performing the required work under this contract, to the satisfaction of the Engineer.

### **PLEASE READ ALL INSTRUCTIONS CAREFULLY BEFORE PREPARING AND SUBMITTING YOUR BID.**

Paper bids shall be prepared and submitted in accordance with SSRS § 102-8 and the following requirements. Failure to comply with any requirement may cause the bid to be irregular and may be grounds for rejection of the bid. Only the Bid Submittal Package pages and all signed addenda shall be submitted as your proposal. **One (1) signed original and two (2) signed copies of the Bid Submittal Package and all signed addenda; shall be submitted as the Bidder’s proposal.**

1. The attached Bid Submittal Package (Bid Submittal Pages 1 of 14 through 14 of 14) furnished by the Department shall be used. The bid shall be submitted on the same proposal that has been furnished to the bidder by the Department. Copies of previous proposals shall be rejected.
2. All entries on the Contract Bid Form, including signatures shall be written in ink or typed.
3. The Bidder shall submit a unit price for each item listed in the Contract Bid Form. The Unit Price for the various contract items shall be written in figures. **Unit Prices shall be rounded off by the Bidder to contain no more than TWO (2) decimal places.**
4. An Amount Bid shall be entered in the Contract Bid Form for each item that a Unit Price has been entered. The Amount Bid for each item shall be determined by multiplying each Unit Price by the quantity for that item, and shall be written in figures in the Amount Bid column in the Contract Bid Sheet.
5. The total bid shall be written in figures in the Total Bid for Project section in the Contract Bid Form. The Total Bid for Project shall be determined by adding the Amount Bid for each item.
6. Changes to any entry shall be made by marking through the entry in ink and making the correct entry adjacent thereto in ink. A representative of the Bidder shall initial the change in ink. Do not use correction fluid, correction tape or similar product to make corrections.
7. The bid shall be properly executed on the included **Execution of Bid – Non-collusion Affidavit, Debarment Certification and Gift Ban Certification** form. All bids are to include the following information:
  - a. Name of corporation, partnership, limited liability company, joint venture, individual or firm, submitting bid.  
**Corporations that have a corporate seal should include it on the bid.**
  - b. Name of individual or representative submitting bid and position or title held on behalf of the bidder.
  - c. Name, signature, and position or title of witness.
8. The bid shall not contain any unauthorized additions, deletions, or conditional bids.
9. The Bidder shall not add any provision reserving the right to accept or reject an award, or to enter into a contract pursuant to an award.
10. The Bid Submittal Package shall be placed in a sealed envelope and shall be delivered to and received in the DOT Purchasing Section by **2:00 pm on February 16, 2022** at the address indicated in the table below:

MAILING ADDRESS FOR DELIVER OF BID VIA U.S. POSTAL SERVICE	OFFICE ADDRESS FOR DELIVERY BY ANY OTHER MEANS, SPECIAL DELIVERY, HAND DELIVERY, OVERNIGHT DELIVERY OR BY ANY OTHER CARRIER
BID NUMBER: 54-CA-08-12009199 Attn: Christian Andresen North Carolina Department of Transportation Purchasing Section Address: 1510 Mail Service Center Raleigh, NC 27699-1510	BID NUMBER: 54-CA-08-12009199 Attn: Christian Andresen North Carolina Department of Transportation Purchasing Section Address: 1 South Wilmington Street, Room 334B Raleigh, NC 27601

**IMPORTANT NOTE:** All paper bids shall be physically delivered to the office address listed above on or before the bid deadline in order to be considered timely, regardless of method of delivery (including U.S. mail). **This is an absolute requirement.** All risk of late arrival due to unanticipated delay – whether delivered by hand, U.S. Postal Service, courier or other delivery service is entirely on the Vendor. It is the sole responsibility of the Vendor to have the bid physically in this Office by the specified time and date of opening. The time of delivery will be marked on each bid when received, and any bid received after the bid submission deadline will be rejected. Sealed bids, subject to the conditions made a part hereof, will be received at the address indicated in the table in this Section, for furnishing and delivering the commodity or service as described herein.

Note that the U.S. Postal Service does not deliver mail to the specified office address but to the State’s Mail Service Center. Vendors are cautioned that bids sent via U.S. Mail, including Express Mail, may not be delivered by the Mail Service Center to the agency’s purchasing office on the due date in time to meet the bid deadline. All Vendors are urged to take the possibility of delay into account when submitting a bid.

All bids shall be submitted in a sealed envelope. Clearly mark each package with: (1) Vendor name; (2) the IFB number; and (3) the due date. Address the package(s) for delivery as shown in the table above.

Bids shall be marked on the outside of the sealed envelope with the Vendor’s name, IFB number, and date and time of opening. If Vendor is submitting more than one bid, each bid shall be submitted in a separate sealed envelope and marked accordingly. For delivery purposes, separate sealed bids from a single Vendor may be included in the same outer package. Do not include bids for more than one solicitation in the same package.

Failure to address proposals correctly could result in delayed delivery service.

**OPENING OF BIDS**

**Bids subject to the conditions made a part hereof will be received until 2:00 pm on February 16, 2022 and then publicly opened for furnishing the services as described herein.**

**Opening of bids is to be in the NCDOT Transportation Building Complex located at 1 South Wilmington Street, Raleigh 27601.**

**NOTE: Parking at the Transportation Building Complex is limited. Arrive early!**

**BID SUBMITTAL PACKAGE**

Litter/Debris Removal and Recycling  
NCDOT Highway Division 8  
Richmond, Montgomery and Randolph Counties

**DATE**

January 27, 2022

**PROPOSAL**

54-CA-08-12009199

**CONTRACTING AGENCY**

State of North Carolina  
Department of Transportation  
Raleigh, North Carolina

**SMALL BUSINESS ENTERPRISE CONTRACT**

Bidder: \_\_\_\_\_

*Company Name*

**NORTH CAROLINA DEPARTMENT OF TRANSPORTATION  
CONTRACT BID FORM**

**BID PROPOSAL NO.:** 54-CA-08-12009199

**WBS ELEMENT NOS.:** 8RE - Various

**COUNTIES:** Division 8 – Richmond, Montgomery and Randolph Counties

**TYPE OF WORK:** Litter/Debris Removal and Recycling on Interstate, Primary and Secondary Roads

LINE NO.	SEC NO.	ITEM DESCRIPTION	EST. QUANT.	UNIT	UNIT PRICE	AMOUNT BID
1	SP	Routine Litter/Debris Removal and Recycling on Interstate Highways	454	MI		
2	SP	Routine Litter/Debris Removal and Recycling on Primary Divided Highways	246	MI		
3	SP	Routine Litter/Debris Removal and Recycling on Primary Undivided Highways	1224	MI		
4	SP	Routine Litter/Debris Removal and Recycling on Secondary Undivided Highways	870	MI		
5	SP	On Call Litter/Debris Removal and Recycling, Outside Shoulder	40	SMI		
6	SP	On Call Litter/Debris Removal and Recycling, Median	20	MI		

<b>TOTAL BID FOR PROJECT:</b> \$ _____
--

**THIS SECTION TO BE COMPLETED BY NORTH CAROLINA DEPARTMENT OF TRANSPORTATION**

*This bid has been reviewed in accordance with Article 103-1 of the Standard Specifications for Roads and Structures 2018.*

Reviewed by \_\_\_\_\_ (date)

Accepted by NCDOT \_\_\_\_\_ (date)

*Procurement Specialist III*

**CONTRACTOR INFORMATION**

Company Name \_\_\_\_\_

Contractor License Number: \_\_\_\_\_

Address: \_\_\_\_\_

Phone: \_\_\_\_\_

Email Address: \_\_\_\_\_

Name of individual authorized to answer questions concerning the information contained herein:

Name: \_\_\_\_\_

Telephone Number(s): \_\_\_\_\_

Email Address: \_\_\_\_\_



**FEDERAL EMPLOYER IDENTIFICATION NUMBER**

The Federal Employer Identification Number or alternate identification number (e.g., Social Security Number) is used for internal processing, including bid tabulation.

Pursuant to N.C.G.S. § 132-1.10(b) this identification number shall not be released to the public. This page is segregated for ease of redaction pursuant to a valid public records request.

---

Identification Number

This page will be removed and shredded, or otherwise kept confidential, before the procurement file is made available for public inspection.

**CONTRACTOR'S WORK EXPERIENCE AND REFERENCES**

**Bidders shall supply a minimum of three (3) references covering work experience on a contract basis, related to litter/debris removal and recycling services. These references are to include private commercial firms, governmental agencies (federal, state, county, city, etc.), and any other references related to litter/debris removal and recycling services which this business or its supervisors, managers, owners or other persons with supervisory responsibility for performance of this contract have had within the last three (3) years, or longer if necessary to attain the required number of references. The references are one factor that will be used by the Engineer to determine whether a bidder is "responsible" and capable or able to perform the work necessary under the contract. ALL REFERENCE CONTACT INFORMATION SHOULD BE CURRENT.**

1. Agency or Firm Name: \_\_\_\_\_  
Physical Address: \_\_\_\_\_  
Mailing Address: \_\_\_\_\_  
Contact Person: \_\_\_\_\_ Telephone(s): \_\_\_\_\_  
Email address: \_\_\_\_\_  
Length of Contract: \_\_\_\_\_ Dates of Contract: \_\_\_\_\_

1. Agency or Firm Name: \_\_\_\_\_  
Physical Address: \_\_\_\_\_  
Mailing Address: \_\_\_\_\_  
Contact Person: \_\_\_\_\_ Telephone(s): \_\_\_\_\_  
Email address: \_\_\_\_\_  
Length of Contract: \_\_\_\_\_ Dates of Contract: \_\_\_\_\_

3. Agency or Firm Name: \_\_\_\_\_  
Physical Address: \_\_\_\_\_  
Mailing Address: \_\_\_\_\_  
Contact Person: \_\_\_\_\_ Telephone(s): \_\_\_\_\_  
Email address: \_\_\_\_\_  
Length of Contract: \_\_\_\_\_ Dates of Contract: \_\_\_\_\_

**EXECUTION OF BID**

**NON-COLLUSION, DEBARMENT AND GIFT BAN CERTIFICATION**

**CORPORATION**

The bidder being duly sworn, solemnly swears (or affirms) that neither he, nor any official, agent or employee has entered into any agreement, participated in any collusion, or otherwise taken any action which is in restraint of free competitive bidding in connection with any bid or contract, that the bidder has not been convicted of violating *N.C.G.S. §133-24* within the last three years, and that the bidder intends to do the work with his own bona fide employees or subcontractors and will not bid for the benefit of another contractor.

By submitting this non-collusion, debarment and gift ban certification, the Contractor is attesting his status under penalty of perjury under the laws of the United States in accordance with the Debarment Certification attached, provided that the Debarment Certification also includes any required statements concerning exceptions that are applicable.

*N.C.G.S. §133-32* and Executive Order 24 prohibit the offer to, or acceptance by, any State Employee of any gift from anyone with a contract with the State, or from any person seeking to do business with the State. By execution of any response in this procurement, you attest, for your entire organization and its employees or agents, that you are not aware that any such gift has been offered, accepted, or promised by any employees of your organization.

**SIGNATURE OF PREQUALIFIED BIDDER**

\_\_\_\_\_ Full name of Corporation

\_\_\_\_\_ Address as Prequalified

Attest \_\_\_\_\_ By \_\_\_\_\_  
Secretary/Assistant Secretary President/Vice President/Assistant Vice President  
(Select appropriate title) (Select appropriate title)

\_\_\_\_\_ Print or type Signer's name \_\_\_\_\_ Print or type Signer's name

**CORPORATE SEAL**

**EXECUTION OF BID**

**NON-COLLUSION, DEBARMENT AND GIFT BAN CERTIFICATION**

**PARTNERSHIP**

The bidder, being duly sworn, solemnly swears (or affirms) that neither he, nor any official, agent or employee has entered into any agreement, participated in any collusion, or otherwise taken any action which is in restraint of free competitive bidding in connection with any bid or contract, that the bidder has not been convicted of violating *N.C.G.S. § 133-24* within the last three years, and that the bidder intends to do the work with its own bona fide employees or subcontractors and will not bid for the benefit of another contractor.

By submitting this non-collusion, debarment and gift ban certification, the Contractor is attesting his status under penalty of perjury under the laws of the United States in accordance with the Debarment Certification attached, provided that the Debarment Certification also includes any required statements concerning exceptions that are applicable.

*N.C.G.S. § 133-32* and Executive Order 24 prohibit the offer to, or acceptance by, any State Employee of any gift from anyone with a contract with the State, or from any person seeking to do business with the State. By execution of any response in this procurement, you attest, for your entire organization and its employees or agents, that you are not aware that any such gift has been offered, accepted, or promised by any employees of your organization.

**SIGNATURE OF PREQUALIFIED BIDDER**

---

Full Name of Partnership

---

Address as Prequalified

---

Signature of Witness

---

Signature of Partner

---

Print or Type Signer's Name

---

Print or Type Signer's Name

**EXECUTION OF BID**

**NON-COLLUSION, DEBARMENT AND GIFT BAN CERTIFICATION**

**LIMITED LIABILITY COMPANY**

The bidder, being duly sworn, solemnly swears (or affirms) that neither he, nor any official, agent or employee has entered into any agreement, participated in any collusion, or otherwise taken any action which is in restraint of free competitive bidding in connection with any bid or contract, that the bidder has not been convicted of violating *N.C.G.S. § 133-24* within the last three years, and that the bidder intends to do the work with its own bona fide employees or subcontractors and will not bid for the benefit of another contractor.

By submitting this non-collusion, debarment and gift ban certification, the Contractor is attesting his status under penalty of perjury under the laws of the United States in accordance with the Debarment Certification attached, provided that the Debarment Certification also includes any required statements concerning exceptions that are applicable.

*N.C.G.S. § 133-32* and Executive Order 24 prohibit the offer to, or acceptance by, any State Employee of any gift from anyone with a contract with the State, or from any person seeking to do business with the State. By execution of any response in this procurement, you attest, for your entire organization and its employees or agents, that you are not aware that any such gift has been offered, accepted, or promised by any employees of your organization.

**SIGNATURE OF PREQUALIFIED BIDDER**

---

Full Name of Firm

---

Address as Prequalified

---

Signature of Witness

---

Signature of Member/Manager/Authorized Agent  
*(Select appropriate Title)*

---

Print or Type Signer's Name

---

Print or Type Signer's Name

**EXECUTION OF BID  
NON-COLLUSION, DEBARMENT AND GIFT BAN CERTIFICATION**

**JOINT VENTURE (2) or (3)**

The bidder, being duly sworn, solemnly swears (or affirms) that neither he, nor any official, agent or employee has entered into any agreement, participated in any collusion, or otherwise taken any action which is in restraint of free competitive bidding in connection with any bid or contract, that the bidder has not been convicted of violating N.C.G.S. § 133-24 within the last three years, and that the bidder intends to do the work with its own bona fide employees or subcontractors and will not bid for the benefit of another contractor.

By submitting this non-collusion, debarment and gift ban certification, the Contractor is attesting his status under penalty of perjury under the laws of the United States in accordance with the Debarment Certification attached, provided that the Debarment Certification also includes any required statements concerning exceptions that are applicable.

N.C.G.S. § 133-32 and Executive Order 24 prohibit the offer to, or acceptance by, any State Employee of any gift from anyone with a contract with the State, or from any person seeking to do business with the State. By execution of any response in this procurement, you attest, for your entire organization and its employees or agents, that you are not aware that any such gift has been offered, accepted, or promised by any employees of your organization.

**SIGNATURE OF PREQUALIFIED BIDDER**

Instructions: **2 Joint Venturers** Fill in lines (1), (2) and (3) and execute. **3 Joint Venturers** Fill in lines (1), (2), (3) and (4) and execute. On Line (1), fill in the name of the Joint Venture Company. On Line (2), fill in the name of one of the joint venturers and execute below in the appropriate manner. On Line (3), print or type the name of the other joint venturer and execute below in the appropriate manner. On Line (4), fill in the name of the third joint venturer, if applicable and execute below in the appropriate manner.

(1) \_\_\_\_\_  
Name of Joint Venture

(2) \_\_\_\_\_  
Name of Contractor

\_\_\_\_\_  
Address as Prequalified

BY

\_\_\_\_\_  
Signature of Witness or Attest

\_\_\_\_\_  
Signature of Contractor

\_\_\_\_\_  
Print or Type Signer's Name

\_\_\_\_\_  
Print or Type Signer's Name

*If Corporation, affix Corporate Seal* AND

(3) \_\_\_\_\_  
Name of Contractor

\_\_\_\_\_  
Address as Prequalified

BY

\_\_\_\_\_  
Signature of Witness or Attest

\_\_\_\_\_  
Signature of Contractor

\_\_\_\_\_  
Print or Type Signer's Name

\_\_\_\_\_  
Print or Type Signer's Name

*If Corporation, affix Corporate Seal* AND

(4) \_\_\_\_\_  
Name of Contractor

\_\_\_\_\_  
Address as Prequalified

BY

\_\_\_\_\_  
Signature of Witness or Attest

\_\_\_\_\_  
Signature of Contractor

\_\_\_\_\_  
Print or Type Signer's Name

\_\_\_\_\_  
Print or Type Signer's Name

*If Corporation, affix Corporate Seal*

**EXECUTION OF BID**

**NON-COLLUSION, DEBARMENT AND GIFT BAN CERTIFICATION**

**INDIVIDUAL DOING BUSINESS UNDER A FIRM NAME**

The bidder, being duly sworn, solemnly swears (or affirms) that neither he, nor any official, agent or employee has entered into any agreement, participated in any collusion, or otherwise taken any action which is in restraint of free competitive bidding in connection with any bid or contract, that the bidder has not been convicted of violating *N.C.G.S. § 133-24* within the last three years, and that the bidder intends to do the work with its own bona fide employees or subcontractors and will not bid for the benefit of another contractor.

By submitting this non-collusion, debarment and gift ban certification, the Contractor is attesting his status under penalty of perjury under the laws of the United States in accordance with the Debarment Certification attached, provided that the Debarment Certification also includes any required statements concerning exceptions that are applicable.

*N.C.G.S. § 133-32* and Executive Order 24 prohibit the offer to, or acceptance by, any State Employee of any gift from anyone with a contract with the State, or from any person seeking to do business with the State. By execution of any response in this procurement, you attest, for your entire organization and its employees or agents, that you are not aware that any such gift has been offered, accepted, or promised by any employees of your organization.

**SIGNATURE OF PREQUALIFIED BIDDER**

Name of Bidder

\_\_\_\_\_

Individual Name

Trading and Doing Business As

\_\_\_\_\_

Full name of Firm

\_\_\_\_\_

Address as Prequalified

Signature of Witness

\_\_\_\_\_

Signature of Bidder, Individual

Print or Type Signer's Name

\_\_\_\_\_

Print or Type Signer's Name

\_\_\_\_\_

**EXECUTION OF BID**

**NON-COLLUSION, DEBARMENT AND GIFT BAN CERTIFICATION**

**INDIVIDUAL DOING BUSINESS IN HIS OWN NAME**

The bidder, being duly sworn, solemnly swears (or affirms) that neither he, nor any official, agent or employee has entered into any agreement, participated in any collusion, or otherwise taken any action which is in restraint of free competitive bidding in connection with any bid or contract, that the bidder has not been convicted of violating *N.C.G.S. § 133-24* within the last three years, and that the bidder intends to do the work with its own bona fide employees or subcontractors and will not bid for the benefit of another contractor.

By submitting this non-collusion, debarment and gift ban certification, the Contractor is attesting his status under penalty of perjury under the laws of the United States in accordance with the Debarment Certification attached, provided that the Debarment Certification also includes any required statements concerning exceptions that are applicable.

*N.C.G.S. § 133-32* and Executive Order 24 prohibit the offer to, or acceptance by, any State Employee of any gift from anyone with a contract with the State, or from any person seeking to do business with the State. By execution of any response in this procurement, you attest, for your entire organization and its employees or agents, that you are not aware that any such gift has been offered, accepted, or promised by any employees of your organization.

**SIGNATURE OF PREQUALIFIED BIDDER**

Name of Bidder

\_\_\_\_\_

Print or Type Name

\_\_\_\_\_  
Address as Prequalified

\_\_\_\_\_  
Signature of Bidder, Individually

\_\_\_\_\_  
Print or type Signer's Name

\_\_\_\_\_  
Signature of Witness

\_\_\_\_\_  
Print or type Signer's name



**DEBARMENT CERTIFICATION OF PREQUALIFIED BIDDER**

## Conditions for certification:

1. The prequalified bidder shall provide immediate written notice to the Department if at any time the bidder learns that his certification was erroneous when he submitted his debarment certification or explanation that is file with the Department, or has become erroneous because of changed circumstances.
2. The terms *covered transaction*, *debarred*, *suspended*, *ineligible*, *lower tier covered transaction*, *participant*, *person*, *primary covered transaction*, *principal*, *proposal*, and *voluntarily excluded*, as used in this provision, have the meanings set out in the Definitions and Coverage sections of the rules implementing Executive Order 12549. A copy of the Federal Rules requiring this certification and detailing the definitions and coverages may be obtained from the Contract Officer of the Department.
3. The prequalified bidder agrees by submitting this form that he will not knowingly enter into any lower tier covered transaction with a person who is debarred, suspended, declared ineligible, or voluntarily excluded from participation in NCDOT contracts, unless authorized by the Department.
4. For Federal Aid projects, the prequalified bidder further agrees that by submitting this form he will include the Federal-Aid Provision titled *Required Contract Provisions Federal-Aid Construction Contract (Form FHWA PR 1273)* provided by the Department, without subsequent modification, in all lower tier covered transactions.
5. The prequalified bidder may rely upon a certification of a participant in a lower tier covered transaction that he is not debarred, suspended, ineligible, or voluntarily excluded from the covered transaction, unless he knows that the certification is erroneous. The bidder may decide the method and frequency by which he will determine the eligibility of his subcontractors.
6. Nothing contained in the foregoing shall be construed to require establishment of a system of records in order to render in good faith the certification required by this provision. The knowledge and information of a participant is not required to exceed that which is normally possessed by a prudent person in the ordinary course of business dealings.
7. Except as authorized in paragraph 6 herein, the Department may terminate any contract if the bidder knowingly enters into a lower tier covered transaction with a person who is suspended, debarred, ineligible, or voluntarily excluded from participation in this transaction, in addition to other remedies available by the Federal Government.

**DEBARMENT CERTIFICATION**

The prequalified bidder certifies to the best of his knowledge and belief, that he and his principals:

- a. Are not presently debarred, suspended, proposed for debarment, declared ineligible, or voluntarily excluded from covered transactions by any Federal department or agency;
- b. Have not within a three-year period preceding this proposal been convicted of or had a civil judgment rendered against them for commission of fraud or a criminal offense in connection with obtaining, attempting to obtain, or performing a public (Federal, State or local) transaction or contract under a public transaction; violation of Federal or State antitrust statutes or commission of embezzlement, theft, forgery, bribery, falsification or destruction of records; making false statements; or receiving stolen property;
- c. Are not presently indicted for or otherwise criminally or civilly charged by a governmental entity (Federal, State or local) with commission of any of the offenses enumerated in paragraph b. of this certification; and
- d. Have not within a three-year period preceding this proposal had one or more public transactions (Federal, State or local) terminated for cause or default.
- e. Will submit a revised Debarment Certification immediately if his status changes and will show in his bid proposal an explanation for the change in status.

If the prequalified bidder cannot certify that he is not debarred, he shall provide an explanation with this submittal. An explanation will not necessarily result in denial of participation in a contract.

Failure to submit a non-collusion affidavit and debarment certification will result in the bidder's bid being considered non-responsive.

Check here if an explanation is attached to this certification.

### BID SUBMITTAL PACKAGE CHECKLIST

This checklist has been provided for your benefit to assist you in completing your Bid Submittal Package to help ensure that all necessary items have been completed.

Check Box	Page Number	Description
	1	Cover Sheet.
	2	Contract Bid Form.
	3	Contractor's Information.
	4	Federal Employer Identification Number
	5	Contractor's Work Experience and References, with a minimum of three (3) references included.
	6-13	Execution of Bid Non-Collusion Affidavit, Debarment Certification and Gift Ban Certification, executed.
	14	Bid Submittal Package Checklist
		Addenda, if applicable.
		<b>Submit original and two (2) duplicate copies.</b>
		<b>Mark the original as "Original" and the copies as "Copy".</b>

**YOU MUST BE CERTIFIED AS A SMALL BUSINESS ENTERPRISE (SBE) CONTRACTOR TO BID!**

**End of bid submittal package!**